

M1.(a)	nucleus labelled correctly	1
	cell membrane labelled correctly	1
(b)	mitosis	1
(c)	electron (microscope)	1
(d)	higher magnification	1
(e)	45 (mm)	1
	45 / 250 or 0.18 (mm) <i>allow ecf</i>	1
	180 (μm)	1
	<i>allow 180 (μm) with no working shown for 3 marks</i>	
(f)	0.2 μm	1

[9]

- M2.** (a) chromosomes 1
- (b) diagram showing four separate chromosomes two long and two short (as in diagram 1)
*allow each chromosome shown as two joined chromatids do **not** allow if chromosomes touching each other* 1
- (c) (i) any **two** from:
- can grow into any type of tissue / named tissue
 - used in medical research
 - used to treat human diseases
 - large numbers can be grown
- 2
- (ii) any **two** from:
- expensive
 - grow out of control / ref cancers
 - may be rejected
 - need for drugs (for rest of life)
- 2

[6]

- M3.** (a) cell division / bacterium divides / multiplies / reproduces
allow asexual / mitosis
ignore growth 1
- (b) 18 1
- 18 000 / 18×10^3 / 1.8×10^4
do not accept 1.8 / 1.8^{04} / 1.8^4
allow ecf from wrong count 1
- (c) to kill / destroy other microorganisms / named type
or to prevent contamination
ignore germs / viruses 1
- to prevent other microorganisms affecting the results
or other microorganisms would be counted
allow to give accurate / reliable results 1
- (d) prevent growth of pathogens / disease-causing microorganisms / dangerous
microorganisms
do not accept microorganisms become pathogenic
ignore germs / viruses
*ignore general safety / biohazards / harmful products
produced by bacteria* 1
- (e) to improve the reliability of the investigation / check for anomalies
do not accept accuracy / precision / fairness / validity
ignore averages / repeatability / reproducibility 1

[7]

M4. (a) asexual

1

(b) mitosis

1

(c) genes

1

[3]

- M5.** (a) 2 and 3 1
- (b) cell **P** has an X chromosome; cell **R** has a Y chromosome 1
- (c) any **two** from:
- (formed from) different egg / 2 eggs
 - (formed from) different sperm / 2 sperm
 - have different genes / alleles / chromosomes / DNA
allow genetics 2
- (d) (i) stem cells 1
- (ii) the cells divide 1
- the cells differentiate 1
- (iii) (medical) research / named eg growing organs
or
medical / patient treatment
allow (embryo) cloning
*do **not** allow designer babies / more babies* 1
- (iv) any **one** from:
- ethical / moral / religious objections
ignore cruel / not natural / playing God
 - potential harm to embryo
allow deformed
ignore harm to mother 1

[9]

- M6.** (a) comparisons are **not** required but should be credited
 accept a clear indication of the statement even if incomplete
- can develop into most other types of cell 1
- each cell divides every 30 minutes 1
- low chance of rejection by the patient's immune system 1
- (b) any **three** from:
- cheaper / only costs £1000
*this **must** be comparative*
ignore costs £1000
 - can collect many (stem) cells
 - adults give permission for their own bone marrow to be collected
comparisons are not required but should be credited
 - safe
- 3

[6]

M7. (a) **A** = nucleus

allow phonetic spelling

1

B = (cell) membrane

1

(b) for repair / growth **or** to replace cells

ignore new cells / skin

1

(c) (i) embryos

1

(ii) paralysis

1

[5]

Q1. **Figure 1** shows a human cheek cell viewed under a light microscope.

Figure 1

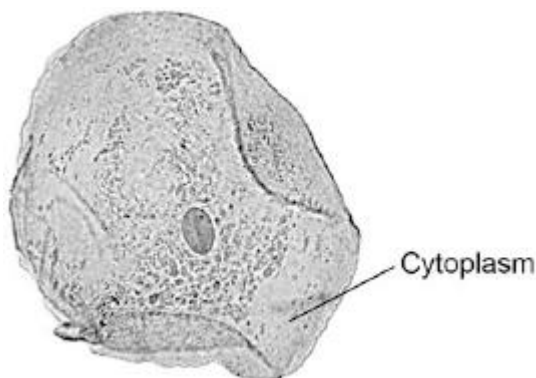

© Ed Reschke/Photolibary/Getty Images

(a) Label the nucleus **and** cell membrane on **Figure 1**.

(2)

(b) Cheek cells are a type of body cell.

Body cells grow through cell division.

What is the name of this type of cell division?

Tick **one** box.

Differentiation

Mitosis

Specialisation

(1)

(c) Ribosomes and mitochondria are **not** shown in **Figure 1**.

What type of microscope is needed to see ribosomes and mitochondria?

.....

(1)

(d) What is the advantage of using the type of microscope you named in part (c)?

Tick **one** box.

Cheaper

Higher magnification

Lower resolution

(1)

- (e) The cheek cell in **Figure 2** is magnified 250 times.
The width of the cell is shown by the line **D** to **E**.

Figure 2

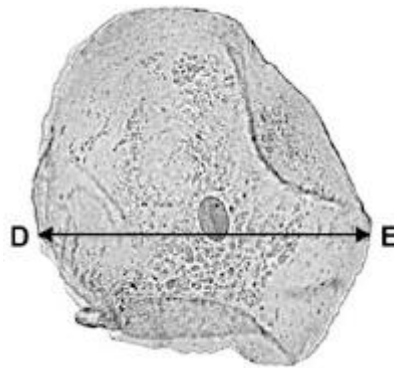

Calculate the width of the cheek cell in micrometres (μm).

Complete the following steps.

Measure the width of the cell using a ruler mm

Use the equation to work out the real width of the cell in mm:

$$\text{real size} = \frac{\text{image size}}{\text{magnification}} \dots\dots\dots \text{mm}$$

Convert mm to μm μm

(3)

- (f) A red blood cell is $8 \mu\text{m}$ diameter.
A bacterial cell is 40 times smaller.
Calculate the diameter of the bacterial cell.

Tick **one** box.

0.02 μm

0.2 μm

2.0 μm

20.0 μm

(1)
(Total 9 marks)

Q2. **Diagram 1** shows the nucleus of a body cell as it begins to divide by mitosis.

Diagram 1

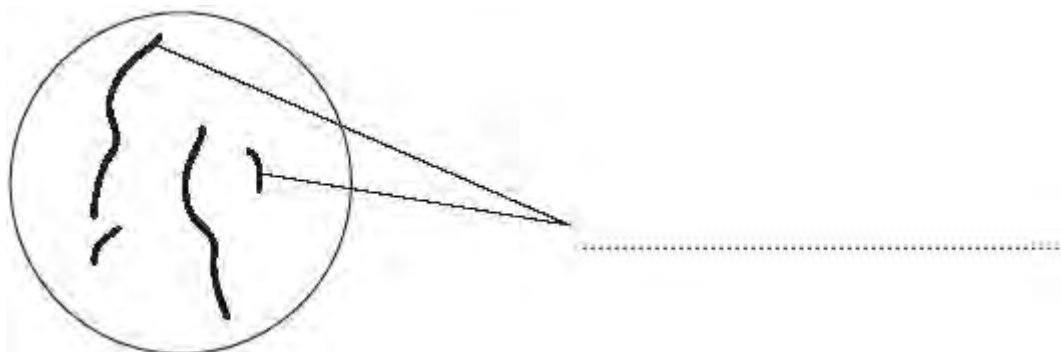

(a) Use a word from the box to label **Diagram 1**.

alleles	chromosomes	gametes
---------	-------------	---------

(1)

(b) Complete **Diagram 2** to show what the nucleus of one of the cells produced by this mitosis would look like.

Diagram 2

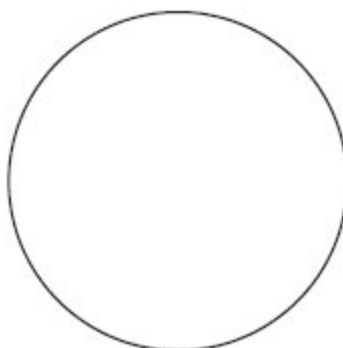

(1)

(c) Stem cells from a recently dead embryo can be grown in special solutions.

Some facts about stem cells are given below.

- Stem cells from an embryo can grow into any type of tissue.
- Stem cells may grow out of control, to form cancers.

- Large numbers of stem cells can be grown in the laboratory.
- Stem cells may be used in medical research or to treat some human diseases.
- Patients treated with stem cells need to take drugs for the rest of their life to prevent rejection.
- Collecting and growing stem cells is expensive.

Use **only** the information above to answer these questions.

(i) Give **two** advantages of using stem cells.

1

.....

2

.....

(2)

(ii) Give **two** disadvantages of using stem cells.

1

.....

2

.....

(2)

(Total 6 marks)

Q3. Some students grew one species of bacterium in a flask.

Diagram 1 shows the flask.

Diagram 1

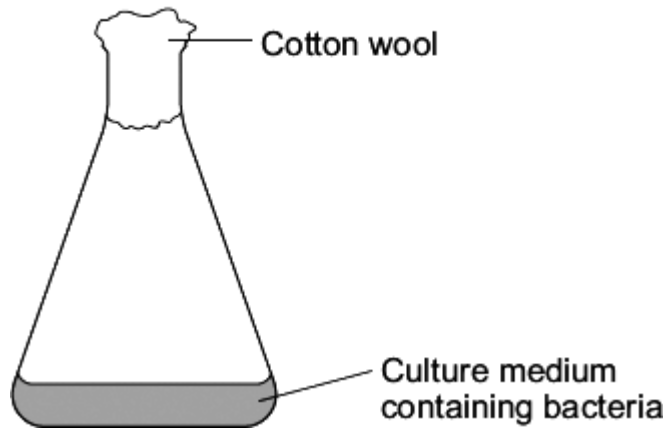

The students wanted to find the number of bacteria in 1 cm^3 of the culture medium.

The students:

- diluted 1 cm^3 of the culture medium from the flask with 999 cm^3 of water
- added 1 cm^3 of diluted culture to sterilised nutrient agar in a Petri dish
- placed the Petri dish in an incubator at $25 \text{ }^\circ\text{C}$.

Diagram 2 shows the Petri dish after 3 days in the incubator.

Diagram 2

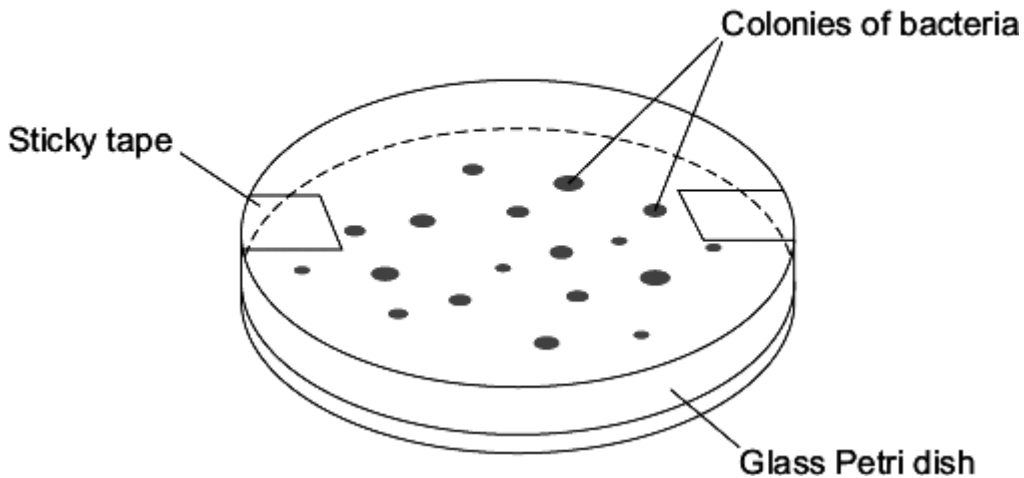

(a) Each colony of bacteria is formed where one bacterium landed on the agar jelly.

How is each colony formed?

.....
.....

(1)

- (b) Complete the following calculation to find how many bacteria there were in 1 cm³ of the undiluted culture.

Number of colonies of bacteria in the Petri dish =

These colonies were formed from 1 cm³ of the culture diluted $\times 1000$.

Therefore, number of bacteria in 1 cm³ of undiluted culture =

(2)

- (c) It is important to sterilise the culture medium and all the apparatus before use.

Explain why.

.....
.....
.....
.....

(2)

- (d) The bacteria would grow faster at 35 °C. In a school laboratory, the Petri dish should **not** be incubated at a temperature higher than 25 °C.

Why?

.....
.....

(1)

- (e) The students decided to repeat their investigation.

Why?

.....
.....

(1)

(Total 7 marks)

Q4. The diagram shows a strawberry plant.

The parent plant grows side shoots.

New plants grow on the side shoots.



Mackean

© D.G.

The new plants will all have the same inherited characteristics as the original parent plant.

Complete the sentences to explain why.

Use words from the box.

asexual	differentiation	embryos	fertilisation
gametes	genes	mitosis	sexual

(a) The new plant is produced by
reproduction.

(1)

(b) In this type of reproduction, body cells divide by
.....

(1)

(c) The new plant has the same as the parent
plant.

(1)

(Total 3 marks)

Q5. A woman gives birth to triplets.
 Two of the triplets are boys and the third is a girl.
 The triplets developed from two egg cells released from the ovary at the same time.

The diagram shows how triplets **A**, **B** and **C** developed.

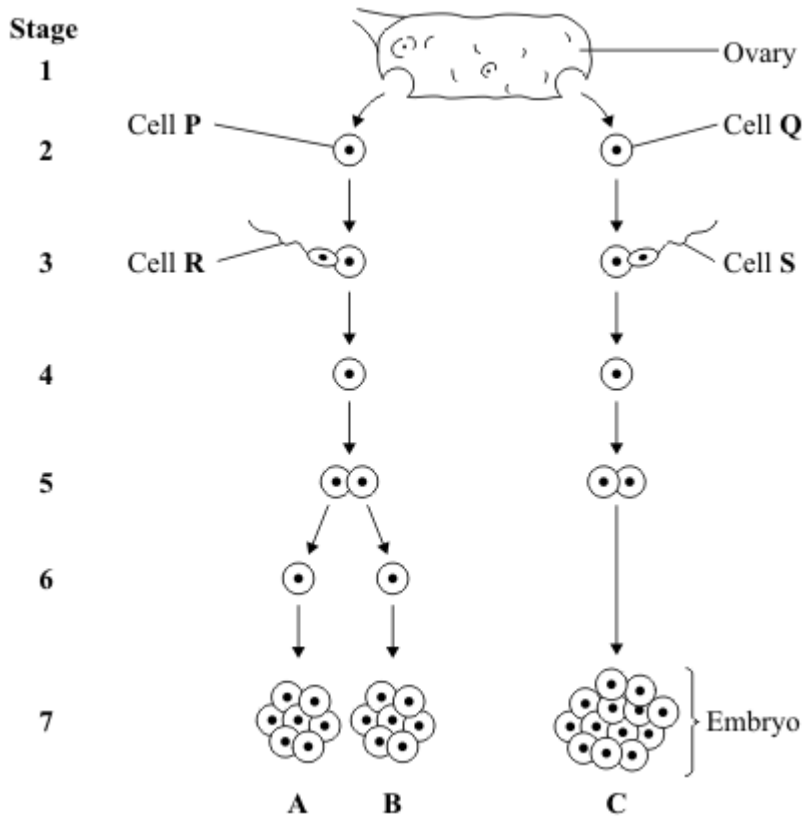

(a) Which stages on the diagram show gametes?

Draw a ring around your answer.

1 and 2 **2 and 3** **3 and 7** **1 and 7**

(1)

(b) Embryo **B** is male.

Which of the following explains why embryo **B** is male?

Tick (✓) **one** box.

Cell **P** has an X chromosome; cell **R** has an X chromosome.

Cell **P** has a Y chromosome; cell **R** has an X chromosome.

Cell **P** has an X chromosome; cell **R** has a Y chromosome.

(1)

(c) The children that develop from embryos **A** and **C** will **not** be identical.

Explain why.

You may use words from the box in your answer.

egg	genes	sperm
------------	--------------	--------------

.....

.....

.....

.....

.....

(2)

(d) Single cells from an embryo at **Stage 7** can be separated and grown in a special solution.

(i) What term describes cells that are grown in this way?

Draw a ring around your answer.

lleles **screened cells** **stem cells**

(1)

(ii) What happens when the cells are placed in the special solution?

Tick (✓) **two** boxes.

The cells divide

The cells fertilise

The cells differentiate

The cells separate

(2)

(iii) Give **one** use of cells grown in this way.

.....
.....

(1)

(iv) Some people might object to using cells from embryos in this way.

Give **one** reason why.

.....
.....
.....

(1)

(Total 9 marks)

Q6. Stem cells can be collected from human embryos and from adult bone marrow. Stem cells can develop into different types of cell.

The table gives information about using these two types of stem cell to treat patients.

Stem cells from human embryos	Stem cells from adult bone marrow
It costs £5000 to collect a few cells.	It costs £1000 to collect many cells.
There are ethical issues in using embryo stem cells.	Adults give permission for their own bone marrow to be collected.
The stem cells can develop into most other types of cell.	The stem cells can develop into only a few types of cell.
Each stem cell divides every 30 minutes.	Each stem cell divides every four hours.
There is a low chance of a patient's immune system rejecting the cells.	There is a high chance of a patient's immune system rejecting the cells.
More research is needed into the use of these stem cells.	Use of these stem cells is considered to be a safe procedure.

Scientists are planning a new way of treating a disease, using stem cells.

Use **only** the information above to answer these questions.

- (a) Give **three** advantages of using stem cells from embryos instead of from adult bone marrow.

- 1
- 2
- 3

(3)

- (b) Give **three** advantages of using stem cells from adult bone marrow instead of from embryos.

- 1
- 2
- 3

(3)

(Total 6 marks)

Q7. Human cells and yeast cells have some parts that are the same.

(a) The diagram shows a yeast cell.

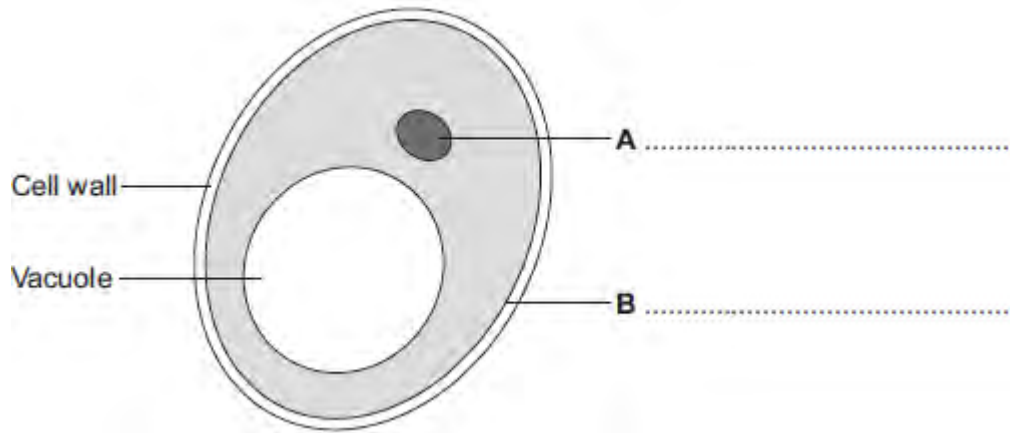

Parts **A** and **B** are found in human cells and in yeast cells. On the diagram, label parts **A** and **B**.

(2)

(b) Many types of cell can divide to form new cells.

Some cells in human skin can divide to make new skin cells.

Why do human skin cells need to divide?

.....
.....

(1)

(c) Human stem cells can develop into many different types of human cell.

(i) Use the correct answer from the box to complete the sentence.

embryos	hair	nerve cells
----------------	-------------	--------------------

Human stem cells may come from

.....

(1)

(ii) Use the correct answer from the box to complete the sentence.

cystic fibrosis	paralysis	polydactyly
------------------------	------------------	--------------------

Human stem cells can be used to treat

.....

(1)
(Total 5 marks)

M1. (a) to kill virus
or
to prevent virus spreading 1

(b) take (stem) cells from meristem
or
tissue culture
allow take cuttings 1

(c) use Benedict's solution 1

glucoses turns solution blue to orange 1

(d) **Level 2 (3–4 marks):**
A detailed and coherent explanation is provided. The student makes logical links between clearly identified, relevant points that explain why plants with TMV have stunted growth.

Level 1 (1–2 marks):
Simple statements are made, but not precisely. The logic is unclear.

0 marks:
No relevant content.

Indicative content

- less photosynthesis because of lack of chlorophyll
- therefore less glucose made
so
- less energy released for growth
- because glucose is needed for respiration
and / or
- therefore less amino acids / proteins / cellulose for growth
- because glucose is needed for making amino acids / proteins / cellulose

4

[8]

M2.

(a)

	Mitosis only	Meiosis only	Both mitosis and meiosis
How cells are replaced	✓		
How gametes are made		✓	
How a fertilised egg undergoes cell division	✓		
How copies of the genetic information are made			✓
How genetically identical cells are produced	✓		

*if more than one tick per row then no mark
ignore first row*

1
1
1
1

(b) (i) (adult) bone marrow

accept (umbilical) cord blood, skin, amniotic fluid / membrane

1

(ii) cells will not be rejected by the patient's body (if they have been produced by therapeutic cloning)

allow easier to obtain linked to embryo stem cells

or

(embryo stem cells) can develop into many different types of cells

allow doesn't need an operation linked to bone marrow

or

(embryo stem cells) not yet differentiated / specialised or undifferentiated

accept embryo cells are pluripotent

- M3.** (a) (i) mitosis
correct spelling only 1
- (ii) replicates / doubles / is copied / duplicates
accept cloned
ignore multiplied / reproduced 1
- (b) fertilisation occurs / fusion (of gametes)
accept converse for asexual, eg none in asexual / just
division in asexual 1
- so leading to mixing of genetic information / genes / DNA / chromosomes
genes / DNA / chromosomes / genetic information comes
from 1 parent in asexual
ignore characteristics 1
- one copy (of each allele / gene / chromosome) from each parent
or
gametes produced by meiosis
or
meiosis causes variation
meiosis must be spelt correctly 1

- M4.** (a) circles round right hand **X** and **Y** gametes
put two ticks or crosses by the circles 2
- (b) 50:50 **or** 1:1 **or** 50% **or** 0.5 **or** $\frac{1}{2}$ equal **or** evens
credit even
do not accept 2:1 or 50 / 50 1
- (c) (i) 23 1
- (ii) 23
credit the same as the one above to be marked consequential 1
- (d) DNA
do not accept nucleic acid 1
- (e) same 1

[7]

Q1.Tobacco mosaic virus (TMV) is a disease affecting plants.

The diagram below shows a leaf infected with TMV.

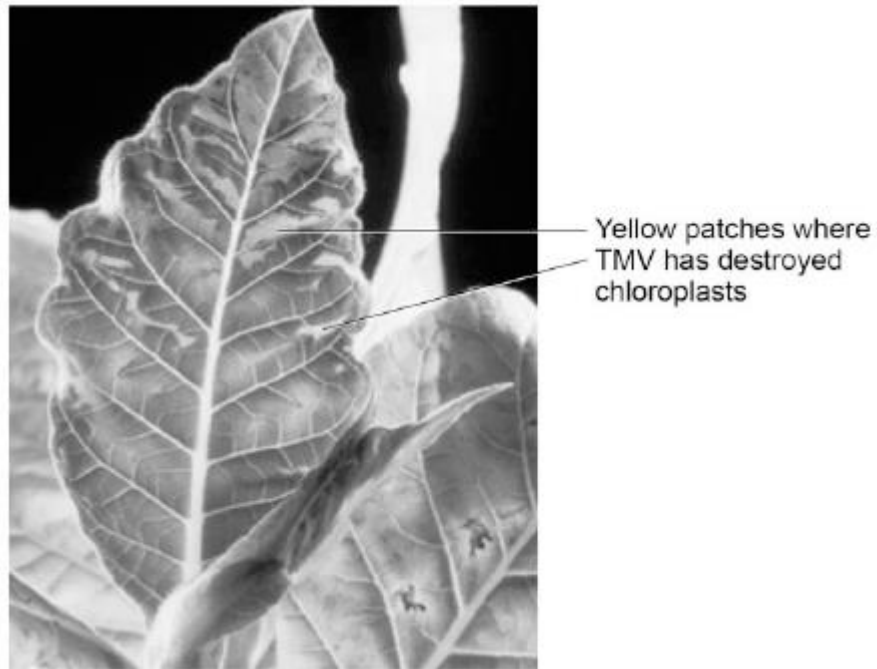

© Nigel Cattlin/Visuals Unlimited/Getty Images

- (a) All tools should be washed in disinfectant after using them on plants infected with TMV.

Suggest why.

.....
.....

(1)

- (b) Scientists produced a single plant that contained a TMV-resistant gene.

Suggest how scientists can use this plant to produce **many** plants with the TMV-resistant gene.

.....
.....

(1)

- (c) Some plants produce fruits which contain glucose.

Describe how you would test for the presence of glucose in fruit.

.....
.....
.....
.....

(2)

(d) TMV can cause plants to produce less chlorophyll.

This causes leaf discoloration.

Explain why plants with TMV have stunted growth.

.....
.....
.....
.....
.....
.....
.....
.....
.....
.....
.....

(4)

(Total 8 marks)

Q2.(a) In humans there are two types of cell division: **mitosis** and **meiosis**.

The table below gives statements about cell division.

Tick (✓) **one** box in each row to show if the statement is true for mitosis only, for meiosis only, or for both mitosis **and** meiosis.

The first row has been done for you.

Statement	Mitosis only	Meiosis only	Both mitosis and meiosis
How cells are replaced	✓		
How gametes are made			
How a fertilised egg undergoes cell division			
How copies of the genetic information are made			
How genetically identical cells are produced			

(4)

(b) Stem cells can be taken from human embryos.

In therapeutic cloning, an embryo is produced that has the same genes as the patient.

(i) Name **one** source of human stem cells, other than human embryos.

.....

(1)

(ii) Stem cells from embryos can be transplanted into patients for medical treatment.

Give **one** advantage of using stem cells from embryos, compared with cells from the source you named in part (i).

.....

.....

(1)

(Total 6 marks)

Q3. The photograph shows some cells in the root of an onion plant.

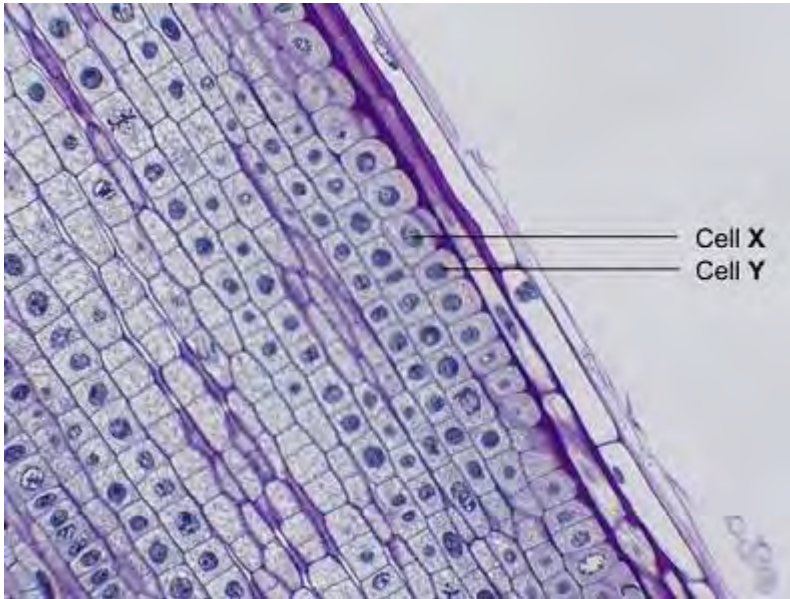

By UAF Center for Distance Education [CC BY 2.0], via Flickr

(a) Cells **X** and **Y** have just been produced by cell division.

(i) Name the type of cell division that produced cells **X** and **Y**.

.....

(1)

(ii) What happens to the genetic material before the cell divides?

.....

(1)

(b) A gardener wanted to produce a new variety of onion.

Explain why sexual reproduction could produce a new variety of onion.

.....
.....
.....
.....
.....
.....

Q4. The genetic diagram shows how the chromosomes divide and combine in human reproduction.

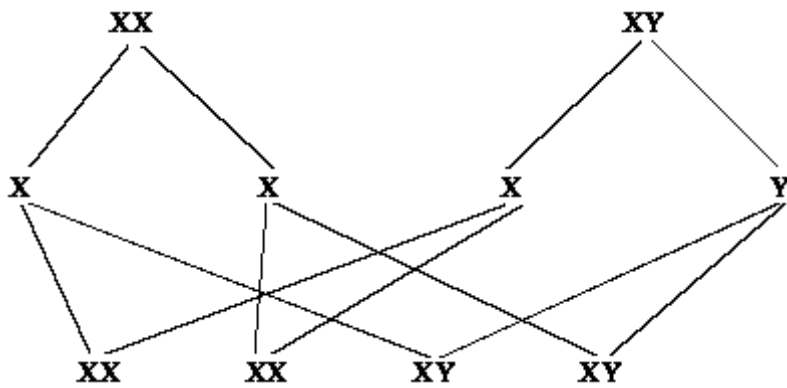

(a) Draw circles around the symbols for the **two** male gametes.

(2)

(b) State the chance of a child being a girl.

.....

(1)

(c) (i) How many pairs of chromosomes are there in a human body cell?

.....

(1)

(ii) How many chromosomes are there in a human egg cell?

.....

(1)

(d) Chromosomes contain genes. From what substance are genes made?

.....

(1)

- (e) In the process of mitosis, how do the number of chromosomes in the daughter cells compare to that in the original cell?

.....

(1)

(Total 7 marks)

- M1.** (a) **C** 1
- (b) cytoplasm **and** cell membrane dividing
accept cytokinesis for 1 mark 1
- to form two identical daughter cells 1
- (c) stage 4 1
- only one cell seen in this stage 1
- (d) $(4 / 36) \times 16 \times 60$ 1
- 107 / 106.7 1
- 110 (minutes)
allow 110 (minutes) with no working shown for 3 marks 1
- (e) binary fission
do not accept mitosis 1

(f) shortage of nutrients / oxygen

1

so cells die

or

death rate = rate of cell division

1

[11]

- M2.** (a) A = meiosis
accept 'mieosis'
*do **not** accept 'miosis'* 1
- B = mitosis
*do **not** accept 'meitosis' etc* 1
- (b) fertilisation allow conception 1
- (c) (i) 23 1
- (ii) 46 1

[5]

M3. any **four** from:

- cells used to treat diseases do not go on to produce a baby
- produces identical cells for research
- cells would not be rejected
- allow cells can form different types of cells
- (immature) egg contains only genetic information / DNA / genes / chromosomes from mother **or** there is only one parent
- asexual / no mixing of genetic material / no sperm involved / no fertilisation **or** chemical causes development
- baby is a clone
- reference to ethical / moral / religious issues
allow ethically wrong
NB cloning is illegal gains 2 marks
ignore unnatural
- risk of damage to the baby
in correct context

[4]

M4. **one** mark for each of the following comparisons to a maximum of **6**

*candidates **must** make a clear comparison*

meiosis

sexual

gametes

ovary **or** testes
or gonads

half number
of chromosomes

haploid **or**
23 chromosomes

reassortment **or**
variation possible
or not identical

4 cells produced

2 divisions

mitosis

asexual

growth

all other cells

same number
of chromosomes

diploid **or**
46 chromosomes

no reassortment
or no variation
or identical

2 cells produced

1 division

[6]

- M5.** (a) any **one** from
- chromosomes in pairs
 - inherited one of each pair from each parent
 - one of each pair in egg **and** one of each pair in sperm
 - so sex cells / gametes can have half the number
allow need to pair during cell division / meiosis
- 1
- (b) any **two** from:
- code
 - combination / sequence of amino acids
 - forming specific / particular proteins / examples
*If **no other mark** gained allow reference to controlling characteristics / appearance for **1** mark*
- 2
- (c) (i) C
- 1
- (ii) 30
- 1
- (d) (i) for growth / repair / replacement / asexual reproduction
*do **not** accept incorrect qualification, eg growth of cells **or** repair of cells*
they equals cells therefore do not accept they grow etc
- 1
- (ii) 44 **or** 22 pairs
- 1

[7]

M6. Marks should **not** be awarded for simply copying the information provided
A mark may be awarded for a comparison between treatments if the answer only involves copied information

any **four** from:

*For all 4 marks to be awarded, there must be at least 1 pro
and 1 con*

embryo stem cells – examples of

pros

- can treat a wide variety / lots of diseases / problems
- many available / plentiful
- using them better than wasting them
- painless

cons

- (possible) harm / death to embryo
- (relatively) untested / unreliable / may not work
*allow long term effects not known
or may be more risky*
- embryo can't be 'asked' / 'embryo rights' idea

adult bone marrow stem cells – examples of

pros

- no ethical issues (in collection) **or** permission given
- quick recovery
- (relatively) safe
allow does not kill (donor) / low risk
- well tried / tested / know they work

cons

- operation hazards eg infection
- few types of cell / tissue produced **or** few diseases / problems treated
- painful so may deter donors

Conclusion to evaluation:

A reasoned conclusion from the evidence

1

[5]

- M7.** (a) (i) DNA replication / copies of genetic material were made
'it' = a chromosome
allow chromosomes replicate / duplicate / are copied
ignore chromosomes divide / split / double 1
- (ii) one copy of each (chromosome / chromatid / strand) to each offspring cell
ignore ref. to gametes and fertilisation 1
- each offspring cell receives a complete set of / the same genetic material
allow 'so offspring (cells) are identical' 1
- (b) (i) meiosis
allow mieosis as the only alternative spelling 1
- (ii) Species A = 4 **and** Species B = 8 1
- (iii) sum of A + B from (b)(ii) e.g. 12 1
- (c) (i) similarities between chromosomes or similarities between flowers described
e.g. shape of petals / pattern on petals / colour / stamens 1
- can breed / can sexually reproduce
allow can reproduce with each other / they can produce offspring 1

(ii) any **two** from:

- offspring contain 3 copies of each gene / of each chromosome / odd number of each of the chromosomes
- some chromosomes unable to pair (in meiosis)
- (viable) gametes not formed / some gametes with extra / too many genes / chromosomes

or some gametes with missing genes / chromosomes

2

[10]

M8. (a) (i) allele expressed even when other allele present **or** expressed if just one copy of allele is present **or** expressed if heterozygous
if present other allele not expressed

1

(ii) 2 affected parents have unaffected child **or** 1 and 2 → **5 / 6**
or if recessive all of **1** and **2**'s children would have CADASIL

1

(iii) heterozygous – has unaffected children **or** because if homozygous all children would have CADASIL

1

(b) genetic diagram including:
accept alternative symbols, if defined

1

correct gametes:

D and **d**
and d (and **d**)
ignore 7 / 8 or male / female

1

derivation of offspring genotypes:

Dd Dd dd dd
*allow just **Dd dd** if $\frac{1}{2}$ -diagram*
allow ecf if correct for student's gametes

1

identification **of Dd** as CADASIL **or dd** as unaffected
allow ecf if correct for student's gametes

1

correct probability: 0.5 / $\frac{1}{2}$ / 1 in 2 / 50% / 1 : 1

1

(c) (i) stem cells can differentiate **or** are undifferentiated / unspecialised

1

can form blood vessel cells / brain cells

or

stem cells can divide

1

(ii) ethical argument - eg no risk of damage to embryo or adult can give consent for removal of cells **or** adult can re-grow skin

more ethical qualified

ignore religion unqualified

or if from a relative then less chance of rejection **or** if from self then no chance of rejection **or** skin cells more accessible

1

[10]

Q1.Figure 1 shows photographs of some animal cells at different stages during the cell cycle.

Figure 1

A

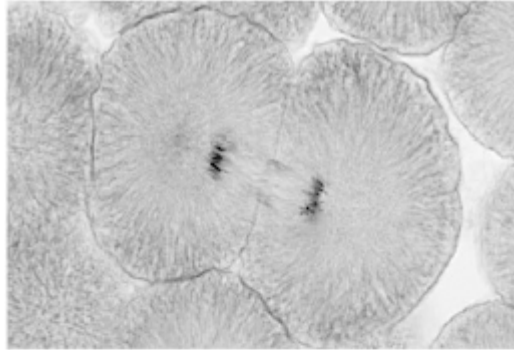

B

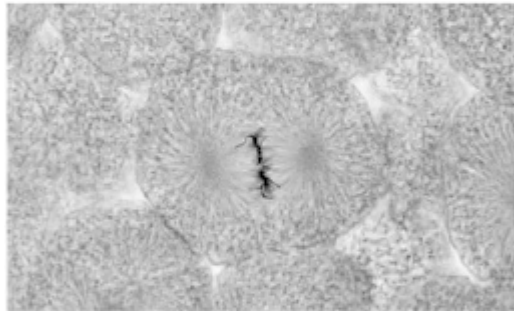

C

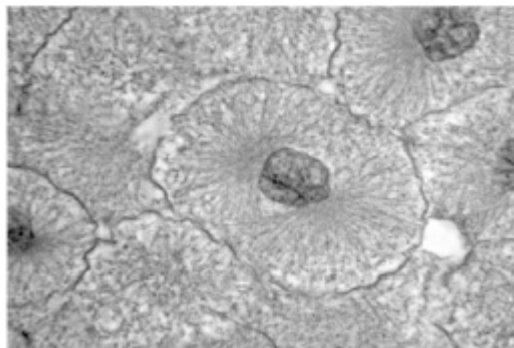

A © Ed Reschke/Photolibary/Getty Images
B © Ed Reschke/Oxford Scientific/Getty Images
C © Ed Reschke/Photolibary/Getty Images

(a) Which photograph in **Figure 1** shows a cell that is **not** going through mitosis?

Tick **one** box.

A **B** **C**

(1)

(b) Describe what is happening in photograph A.

.....
.....
.....
.....
.....

(2)

(c) A student wanted to find out more about the cell cycle.

The student made a slide of an onion root tip.

She counted the number of cells in each stage of the cell cycle in one field of view.

The table below shows the results.

	Stages in the cell cycle					
	Non-dividing cells	Stage 1	Stage 2	Stage 3	Stage 4	Total
Number of cells	20	9	4	2	1	36

Each stage of the cell cycle takes a different amount of time.

Which stage is the fastest in the cell cycle?

Give a reason for your answer.

Stage

Reason

.....

(2)

(d) The cell cycle in an onion root tip cell takes 16 hours.

Calculate the length of time **Stage 2** lasts in a typical cell.

Give your answer to 2 significant figures.

.....

.....

.....

.....

Time in **Stage 2** = minutes

(3)

(e) Bacteria such as *Escherichia coli* undergo cell division similar to mitosis.

Figure 2 shows a growth curve for *E. coli* grown in a nutrient broth.

Figure 2

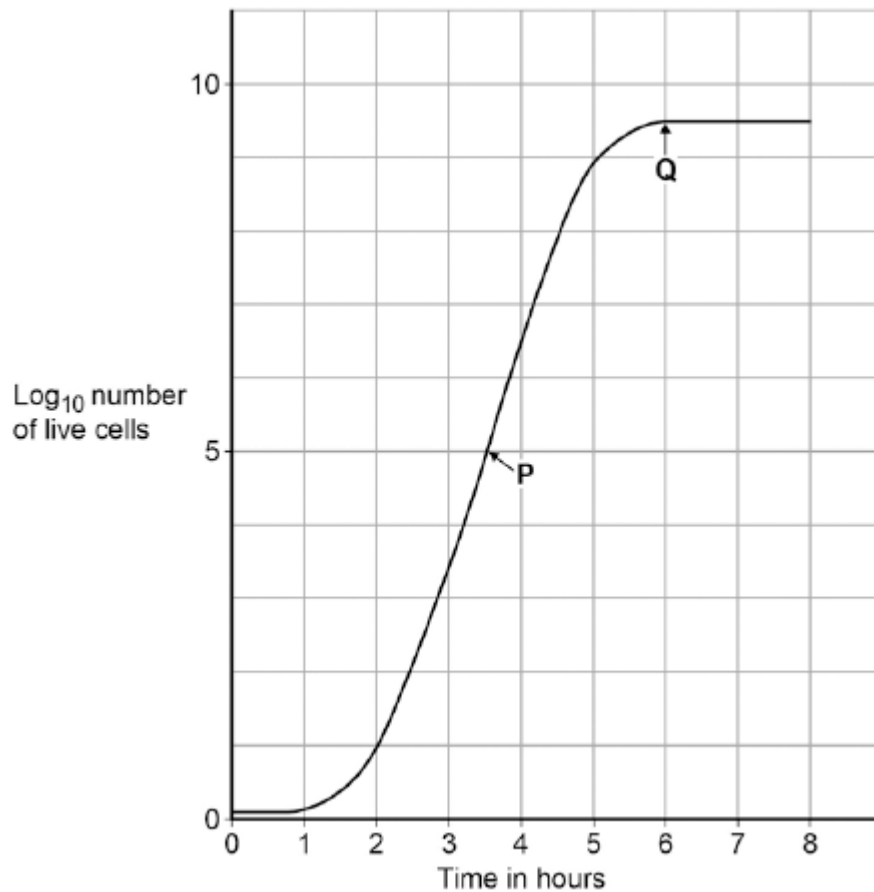

What type of cell division causes the change in number of *E. coli* cells at **P**?

.....

(1)

(f) Suggest why the number of cells levels out at **Q**.

.....

.....

.....

.....

.....

.....

(2)

(Total 11 marks)

Q2. The diagram shows two patterns of cell division. Cell division type **A** is used in gamete formation. Cell division type **B** is used in normal growth.

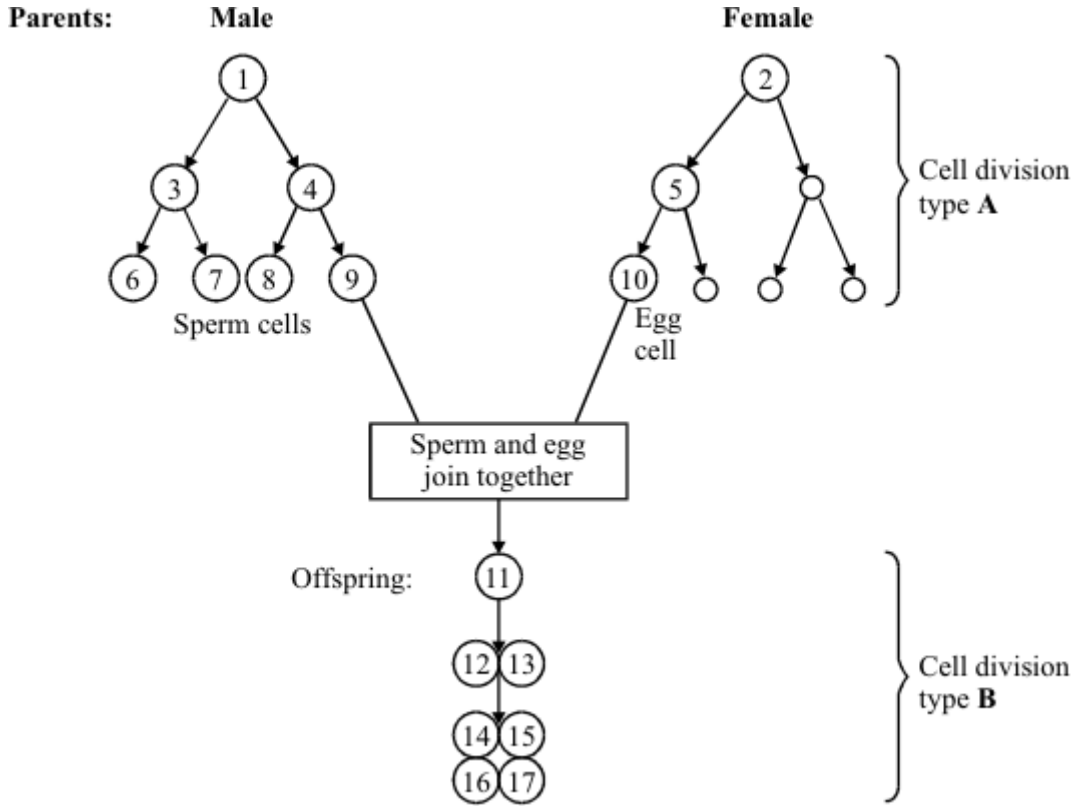

(a) Name the two types of cell division, **A** and **B**, shown in the diagram.

Type **A**

Type **B**

(2)

(b) Name the process in which an egg and sperm join together.

.....

(1)

(c) Cell 1 contains 46 chromosomes. How many chromosomes will there be in:

(i) cell **10**; (1)

(ii) cell **14**?
..... (1)

(Total 5 marks)

Q3. The diagram shows how an immature egg could be used either to produce cells to treat some human diseases or to produce a baby.

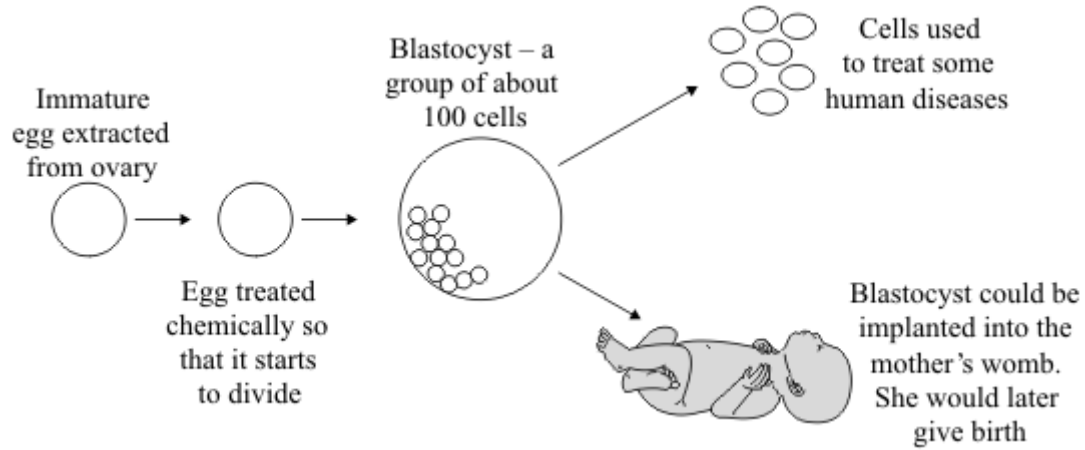

Scientists may be allowed to use this technique to produce cells to treat some human diseases, but not to produce babies.

Using information from the diagram, suggest an explanation for this.

.....

.....

.....

.....

.....

.....

.....

.....

.....

.....

.....

(Total 4 marks)

Q4. Meiosis and mitosis are different types of division in human cells. Compare the two processes by referring to where each takes place and the kind of products that are made.

.....

.....

.....

.....

.....

.....

.....

.....

.....

.....

.....

.....

.....

.....

.....

.....

.....

.....

.....

.....

.....

.....

(Total 6 marks)

Q5. The table shows the number of chromosomes found in each body cell of some different organisms.

Animals		Plants	
Species	Number of chromosomes in each body cell	Species	Number of chromosomes in each body cell
Fruit fly	8	Tomato	24
Goat	60	Potato	44
Human	46	Rice	24

(a) Nearly every organism on earth has an even number of chromosomes in its body cells.

Suggest why.

.....

(1)

(b) Chromosomes contain DNA molecules.

Describe the function of DNA.

.....

(2)

(c) Gametes are made in the testes by meiosis.

(i) Look at the diagrams.

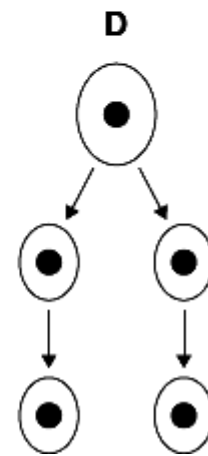
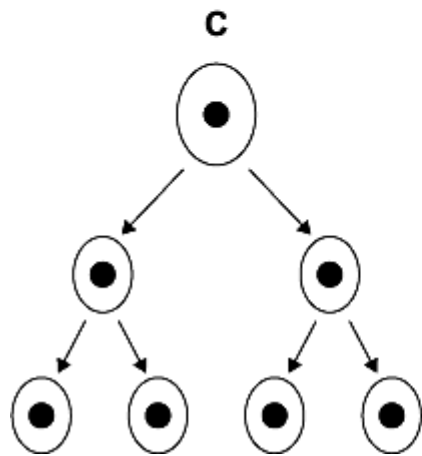
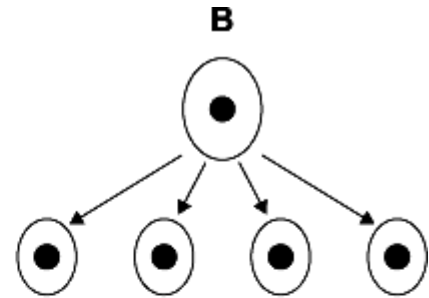
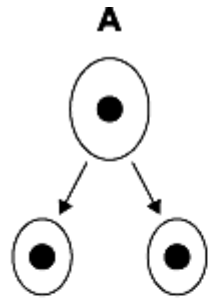

Which diagram, **A**, **B**, **C** or **D**, represents how cell division by meiosis produces

gametes in the testes?

(1)

(ii) How many chromosomes will each goat gamete contain?

.....

(1)

(d) Body cells divide by mitosis.

(i) Why is the ability of body cells to divide important?

.....

.....

(1)

- (ii) When a body cell of a potato plant divides, how many chromosomes will each of the new cells contain?

.....

(1)
(Total 7 marks)

Q6. Read the information about stem cells.

Stem cells are used to treat some human diseases.

Stem cells can be collected from early embryos. These stem cells have not begun to differentiate, so they could be used to produce any kind of cell, tissue or organ. The use of embryonic stem cells to treat human diseases is new and, for some diseases, trials on patients are happening now.

Stem cells can also be collected from adult bone marrow. The operation is simple but may be painful. Stem cells in bone marrow mainly differentiate to form blood cells. These stem cells have been used successfully for many years to treat some kinds of blood disease. Recently there have been trials of other types of stem cell from bone marrow. These stem cells are used to treat diseases such as heart disease.

Evaluate the use of stem cells from embryos or from adult bone marrow for treating human diseases.

You should give a conclusion to your evaluation.

.....

.....

.....

.....

.....

.....

.....

.....

.....

.....

(5)
(Total 5 marks)

Q7. The photographs show the flowers of two closely-related species of plant.

Species A Species B



Images: © iStock/Thinkstock

The drawings show chromosomes from one cell in the root of each plant during cell division.

Species A Species B



**One
chromosome**

**One
chromosome**

(a) The drawings show that each chromosome has two strands of genetic material.

(i) How does a chromosome become two strands?

.....
.....

(1)

(ii) Explain why each chromosome must become two strands before the cell divides.

.....
.....

.....
.....

(2)

(b) For sexual reproduction, the plants produce gametes.

(i) Name the type of cell division that produces gametes.

.....

(1)

(ii) How many chromosomes would there be in a gamete from each of these two plant species?

Species A **Species B**

(1)

(iii) It is possible for gametes from **Species A** to combine with gametes from **Species B** to produce healthy offspring plants. How many chromosomes would there be in each cell of one of the offspring

plants?

(1)

(c) (i) Look back at the information at the start of the question and the information from part (b).

What evidence from these two pieces of information supports the belief that **Species A** and **Species B** evolved from a common ancestor?

.....
.....
.....
.....

(2)

- (ii) For successful gamete production to take place, chromosomes that contain the same genes must pair up.

The drawings showing the chromosomes of **Species A** and of **Species B** are repeated below.

Species A Species B

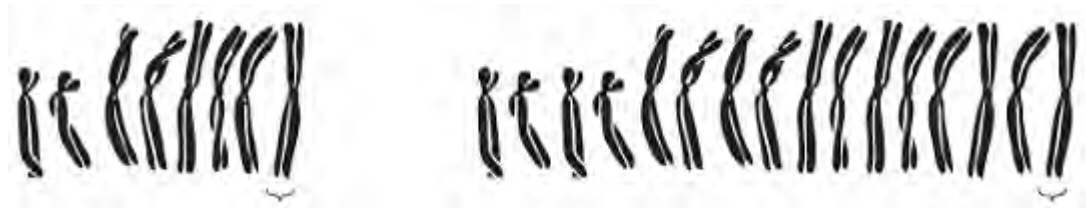

The offspring plants cannot reproduce sexually.

Suggest an explanation for this.

.....
.....
.....
.....
.....
.....

(2)
(Total 10 marks)

Q8. CADASIL is an inherited disorder caused by a dominant allele.

CADASIL leads to weakening of blood vessels in the brain.

The diagram shows the inheritance of CADASIL in one family.

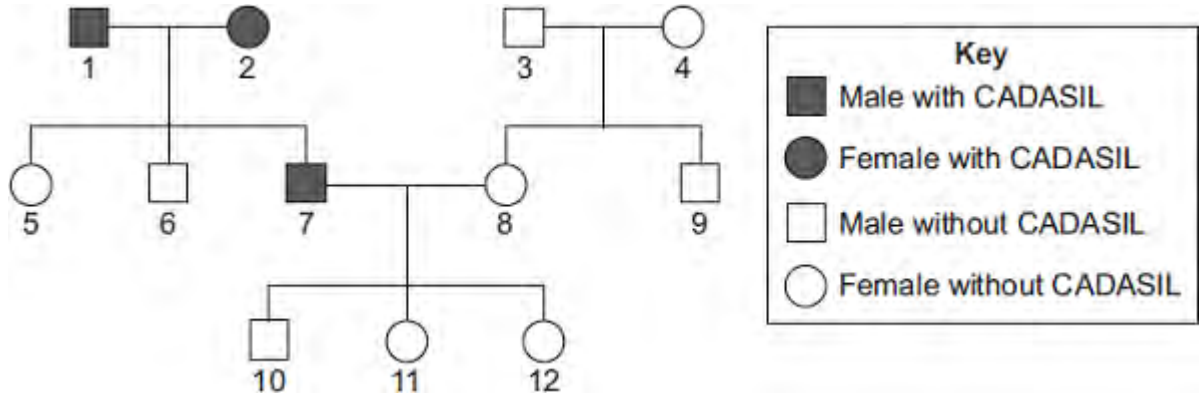

(a) CADASIL is caused by a *dominant allele*.

(i) What is a *dominant allele*?

.....

(1)

(ii) What is the evidence in the diagram that CADASIL is caused by a dominant allele?

.....

(1)

(iii) Person 7 has CADASIL.

Is person 7 homozygous or heterozygous for the CADASIL allele?

Give evidence for your answer from the diagram.

.....

(1)

- (b) Persons **7** and **8** are planning to have another baby.
Use a genetic diagram to find the probability that the new baby will develop into a person with CADASIL.

Use the following symbols to represent alleles.

D = allele for CADASIL

d = allele for not having CADASIL

Probability =

(4)

- (c) Scientists are trying to develop a treatment for CADASIL using stem cells.

Specially treated stem cells would be injected into the damaged part of the brain.

- (i) Why do the scientists use stem cells?

.....
.....
.....
.....

(2)

- (ii) Embryonic stem cells can be obtained by removing a few cells from a human embryo. In 2006, scientists in Japan discovered how to change adult skin cells into stem cells. Suggest **one** advantage of using stem cells from adult skin cells.

.....
.....

(1)

(Total 10 marks)

- M1.(a) (i) A – (cell) wall 1
- B – cytoplasm 1
- C – plasmid 1
- (ii) bacterium cell has cell wall / no nucleus / no mitochondria / plasmids present
accept its DNA / genetic material is not enclosed / it has no nuclear membrane
it = bacterium cell
accept converse for animal cell
ignore flagella 1
- (iii) any **one** from:
 - chloroplast
ignore chlorophyll
 - (permanent) vacuole 1
- (b) (Long tail) moves the sperm / allows the sperm to swim 1
- towards the egg
allow correct reference to other named parts of the female reproductive system 1
- (Mitochondria) release energy (for movement / swimming)
allow supply / produce / provide 1
- in respiration 1

[9]

M2.(a) nucleus labelled correctly 1

cell membrane labelled correctly 1

(b) mitosis 1

(c) electron (microscope) 1

(d) higher magnification 1

(e) 45 (mm) 1

45 / 250 **or** 0.18 (mm)
allow ecf 1

180 (μm) 1

allow 180 (μm) with no working shown for 3 marks

(f) 0.2 μm 1

[9]

M3.(a) (i) 25°C 1

(ii) pathogens 1

(b) D 1

more / most bacteria killed
accept biggest area / ring where no bacteria are growing 1

(c) viruses live inside cells 1

[5]

M4.(a) (i) **C and D**

no mark if more than one box is ticked

1

(ii) any **one** from:

*do **not** allow if other cell parts are given in a list*

- (have) cell wall(s)
- (have) vacuole(s)

1

(b) (i) **A**

apply list principle

1

(ii) **D**

apply list principle

1

(c) respiration

apply list principle

1

[5]

M5.(a) (i) A = nucleus 1

B = (cell) membrane 1

(ii) any **two** from:
ignore shape

- no (cell) wall
- no (large / permanent) vacuole
- no chloroplasts / chlorophyll

2

(b) because high to low oxygen / concentration **or** down gradient
allow 'more / a lot of oxygen molecules outside'
ignore along / across gradient

1

(c) a tissue 1

[6]

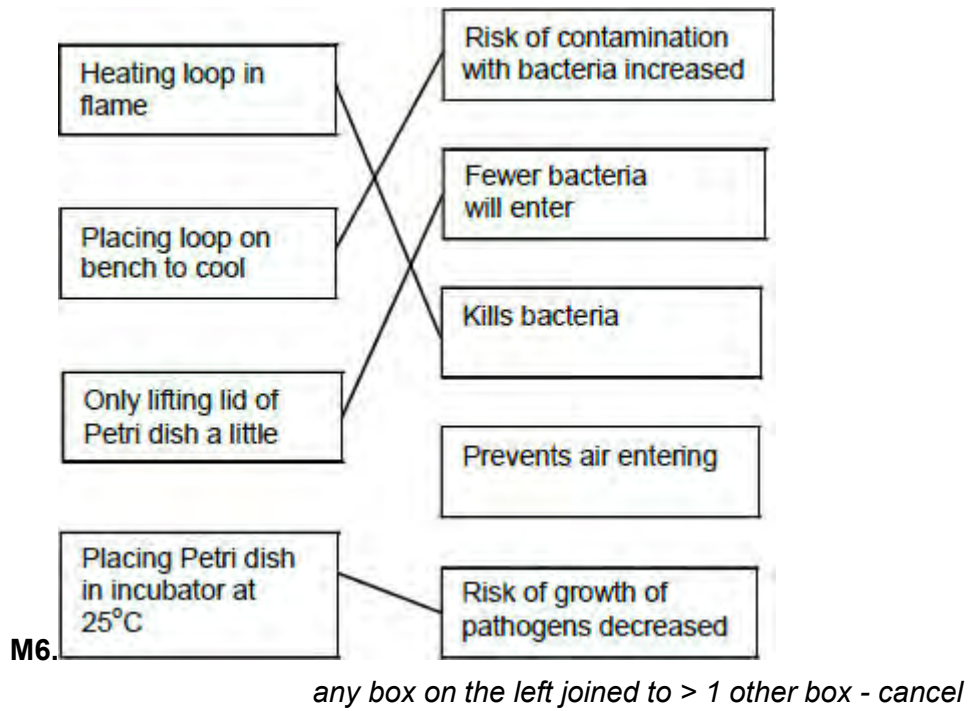

[4]

M7.(a) (i) A = (cell) membrane

1

B = cytoplasm

do not accept cytoplasm

1

(ii) To control the activities of the cell

1

(b)

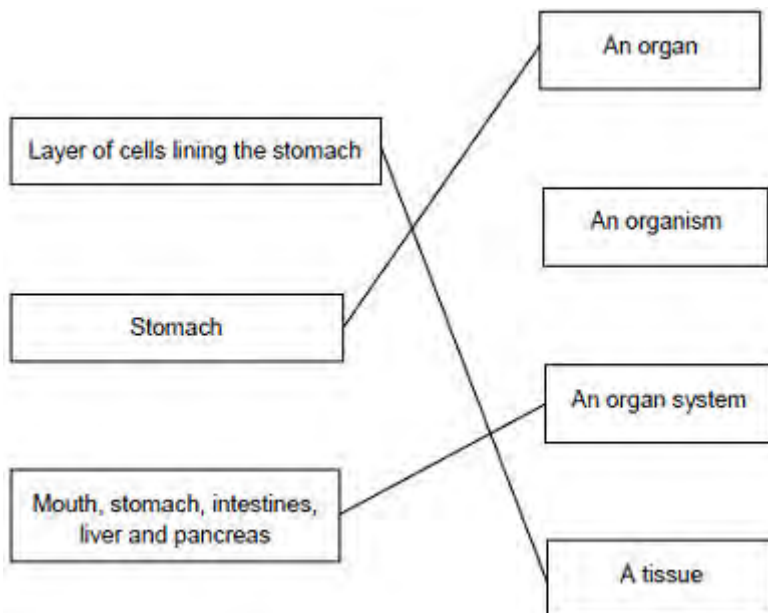

extra lines cancel

3

[6]

M8.(a) (i) Chromosomes 1

(ii) Characteristics 1

(iii) Classify 1

(b) Plants 1

ignore algae

[4]

M9.(a) A (inoculating / wire) loop 1

B Petri dish

allow (agar) plate

ignore ref to culture medium

1

(b) (i) to kill (unwanted) bacteria / microorganisms / microbes

allow fungi

ignore viruses / germs

1

(ii) Using a flame

1

(iii) any **one** from:

- so bacteria / microorganisms / microbes / pathogens / fungi (growing in dish) do not get out

ignore reference to gases

ignore viruses / germs

- so bacteria / microorganisms / microbes / pathogens / fungi (from the air) do not get in.

ignore viruses / germs

1

(c) 25 °C

1

[6]

M10.(a) **A** = nucleus

allow phonetic spelling

1

B = (cell) membrane

1

(b) for repair / growth **or** to replace cells
ignore new cells / skin

1

(c) (i) embryos

1

(ii) paralysis

1

[5]

Q1.(a) The diagram shows the structure of a bacterial cell.

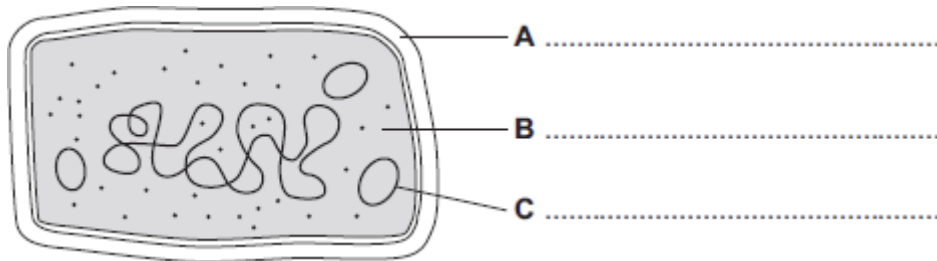

(i) On the diagram use words from the box to label structures **A**, **B** and **C**.

cell membrane	cell wall	chloroplast	cytoplasm	plasmid
---------------	-----------	-------------	-----------	---------

(3)

(ii) Give **one** difference between the structure of the bacterial cell and an animal cell.

.....

(1)

(iii) Name **one** structure that is found in a plant cell but is **not** found in a bacterial or an animal cell.

.....

(1)

(b) Cells can be specialised for a particular job.

The diagram shows the structure of a human sperm cell.

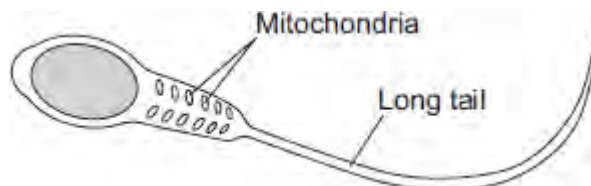

Describe how the long tail and the mitochondria help the sperm to do its job.

Long tail.....

.....

.....

Mitochondria.....

.....

.....

(4)
(Total 9 marks)

Q2.Figure 1 shows a human cheek cell viewed under a light microscope.

Figure 1

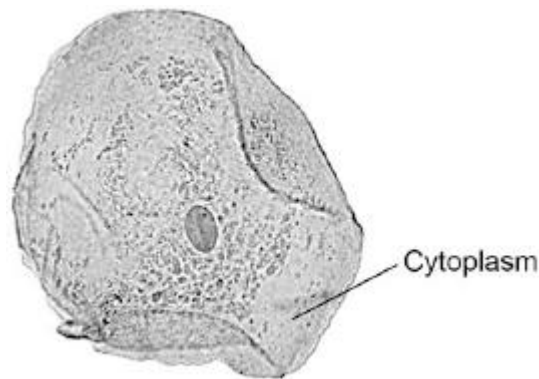

© Ed Reschke/Photolibrary/Getty Images

(a) Label the nucleus **and** cell membrane on **Figure 1**.

(2)

(b) Cheek cells are a type of body cell.

Body cells grow through cell division.

What is the name of this type of cell division?

Tick **one** box.

Differentiation

Mitosis

Specialisation

(1)

(c) Ribosomes and mitochondria are **not** shown in **Figure 1**.

What type of microscope is needed to see ribosomes and mitochondria?

.....

(1)

(d) What is the advantage of using the type of microscope you named in part (c)?

Tick **one** box.

Cheaper

Higher magnification

Lower resolution

(1)

- (e) The cheek cell in **Figure 2** is magnified 250 times.
The width of the cell is shown by the line **D** to **E**.

Figure 2

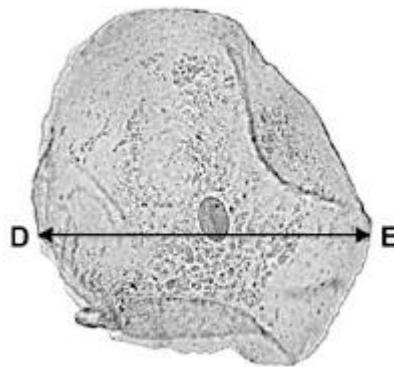

Calculate the width of the cheek cell in micrometres (μm).

Complete the following steps.

Measure the width of the cell using a ruler mm

Use the equation to work out the real width of the cell in mm:

$$\text{real size} = \frac{\text{image size}}{\text{magnification}} \quad \text{..... mm}$$

Convert mm to μm μm

(3)

- (f) A red blood cell is $8 \mu\text{m}$ diameter.
A bacterial cell is 40 times smaller.

Calculate the diameter of the bacterial cell.

Tick **one** box.

0.02 μm

0.2 μm

2.0 μm

20.0 μm

(1)
(Total 9 marks)

Q3. Students in a school investigated the effect of five different antibiotics, **A**, **B**, **C**, **D** and **E**, on one type of bacterium.

The students:

- grew the bacteria on agar jelly in a Petri dish
- soaked separate paper discs in each of the antibiotics
- put the paper discs onto the bacteria in the Petri dish
- put the Petri dish into an incubator.

The diagram shows what the Petri dish looked like after 3 days.

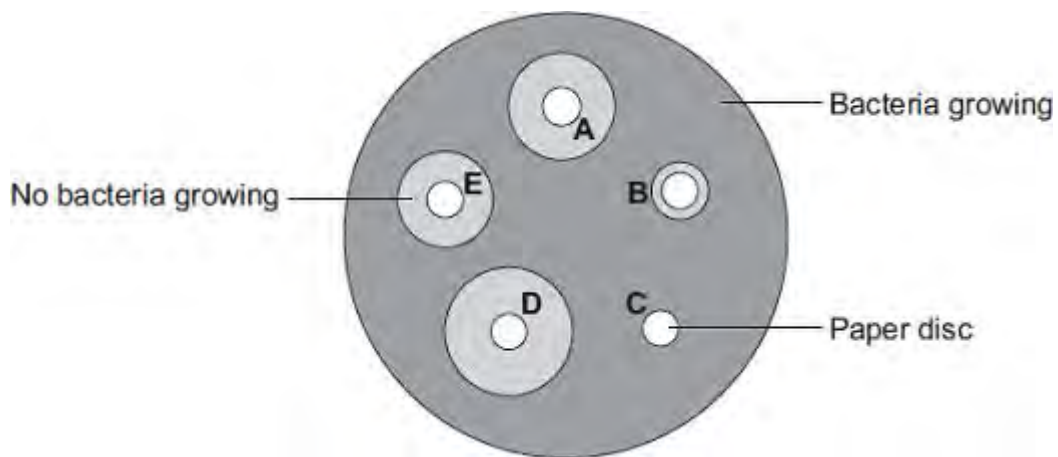

- (a) (i) What is the maximum temperature the incubator should be set at in the school?

Draw a ring around your answer.

10°C 25°C 50°C

(1)

- (ii) Draw a ring around the correct answer to complete the sentence.

The incubator should **not** be set at a higher temperature because the higher

temperature might help the growth of

pathogens.

toxins.

viruses.

(1)

(b) Which antibiotic, **A**, **B**, **C**, **D** or **E**, would be best to treat a disease caused by this type of bacterium?

Write your answer in the box.

Give the reason for your answer.

.....
.....

(2)

(c) Antibiotics **cannot** be used to treat diseases caused by viruses.

Why?

Tick (✓) **one** box.

Viruses are not pathogens

There are too many different types of virus

Viruses live inside cells

(1)
(Total 5 marks)

Q4. The diagrams show four types of cell, **A**, **B**, **C** and **D**.
Two of the cells are plant cells and two are animal cells.

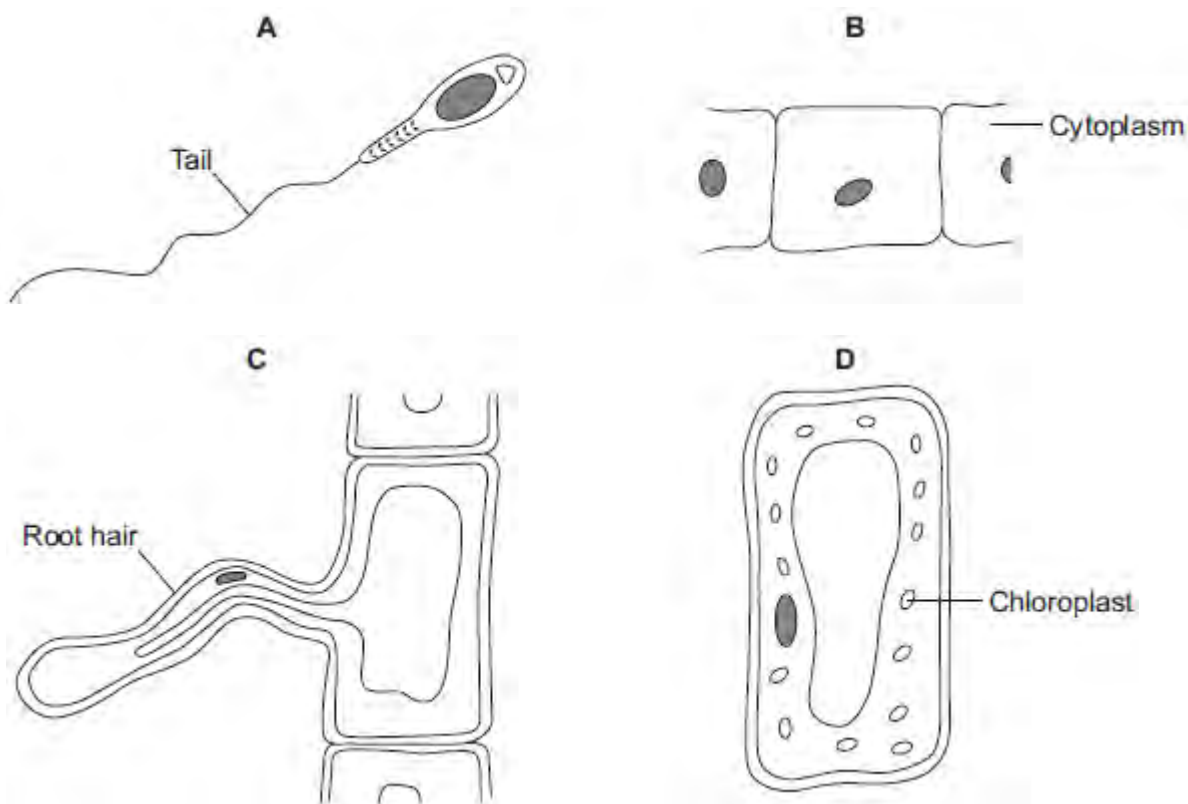

(a) (i) Which **two** of the cells are plant cells?

Tick (✓) **one** box.

A and B

A and D

C and D

(1)

(ii) Give **one** reason for your answer.

.....
.....

(1)

(b) (i) Which cell, **A**, **B**, **C** or **D**, is adapted for swimming?

(1)

(ii) Which cell, **A**, **B**, **C** or **D**, can produce glucose by photosynthesis?

(1)

(c) Cells **A**, **B**, **C** and **D** all use oxygen.

For what process do cells use oxygen?

Draw a ring around **one** answer.

osmosis

photosynthesis

respiration

(1)
(Total 5 marks)

Q5.The diagram shows a cell.

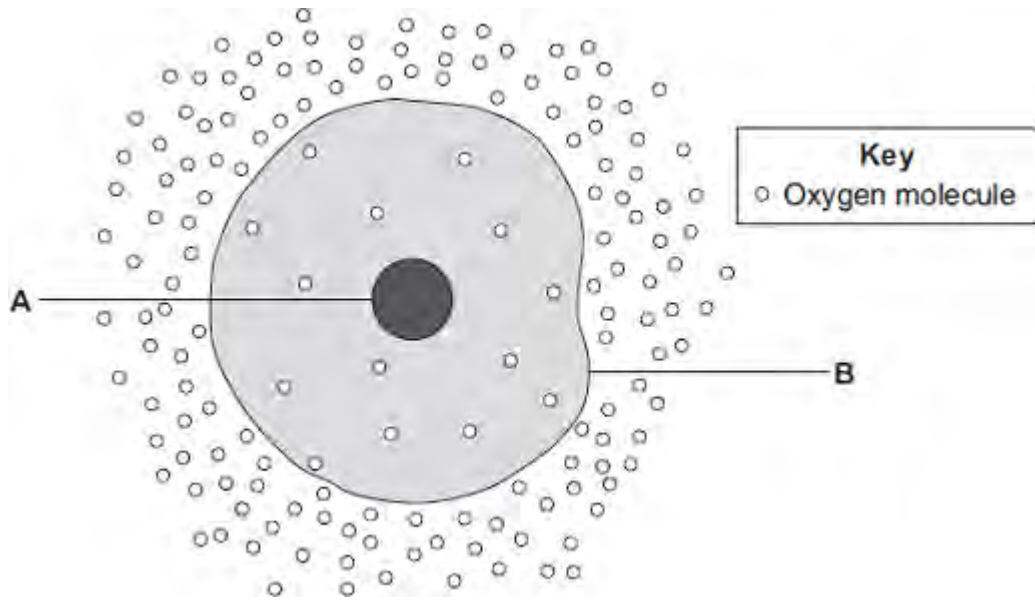

(a) (i) Use words from the box to name the structures labelled **A** and **B** .

cell membrane	chloroplast	cytoplasm	nucleus
---------------	-------------	-----------	---------

A

B

(2)

(ii) The cell in the diagram is an animal cell.

How can you tell it is an animal cell and **not** a plant cell?

Give **two** reasons.

1

.....

2

.....

(2)

(b) Oxygen will diffuse into the cell in the diagram.

Why?

Use information from the diagram.

.....
.....

(1)

(c) The cell shown in the diagram is usually found with similar cells.

Draw a ring around the correct answer to complete the sentence.

Scientists call a group of similar cells

an organ.

a system.

a tissue.

(1)
(Total 6 marks)

Q6.The diagram shows how a student transferred some sour milk from a bottle to a Petri dish of nutrient agar.

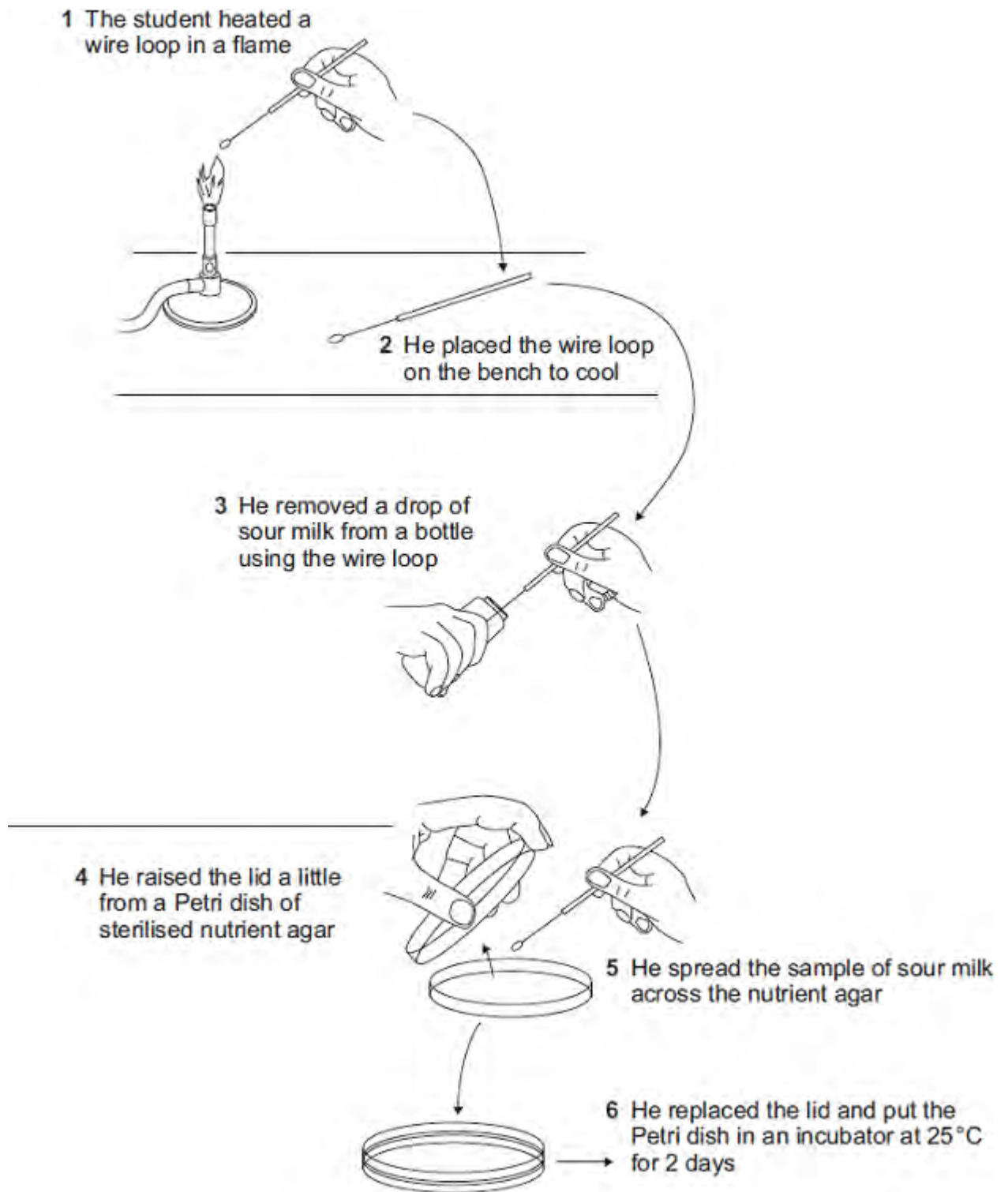

List A gives four actions carried out by the student.
List B gives five possible effects of these actions.

Draw a straight line from each action in **List A** to its effect in **List B**.
Draw only **one** line from each action.

List A – Action

List B – Effect

Heating loop in flame

Risk of contamination with bacteria increased

Placing loop on bench to cool

Fewer bacteria will enter

Only lifting lid of Petri dish a little

Kills bacteria

Placing Petri dish in incubator at 25°C

Prevents air entering

Risk of growth of pathogens decreased

(Total 4 marks)

Q7.The image below shows some cells in the lining of the stomach.

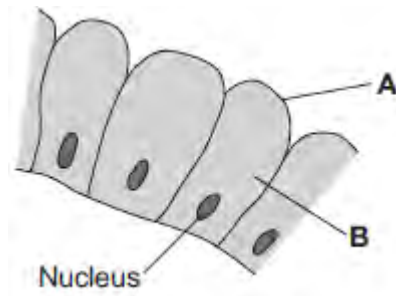

(a) (i) Use words from the box to name structures **A** and **B**.

cell membrane	chloroplast	cytoplasm	vacuole
---------------	-------------	-----------	---------

A

B

(2)

(ii) What is the function of the nucleus?

Tick (✓) **one** box.

To control the activities of the cell

To control movement of substances into and out of the cell

To release energy in respiration

(1)

(b) Draw **one** line from each part of the human body to its correct scientific name.

Part of human body

Layer of cells lining the stomach

Stomach

Mouth, stomach, intestines, liver and pancreas

Scientific name

An organ

An organism

An organ system

A tissue

(3)
(Total 6 marks)

Q8.The diagram below shows a cell.

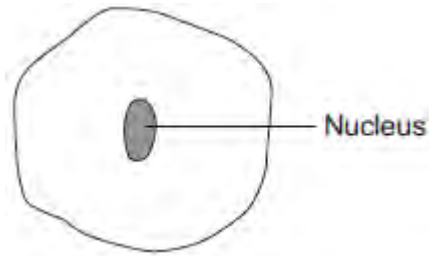

(a) Draw a ring around the correct answer to complete each sentence.

(i) In the nucleus of a cell, genes are part of

chromosomes.
membranes.
receptors.

(1)

(ii) Different genes control different

characteristics
gametes
nuclei

of an organism.

(1)

(iii) Studying the similarities and differences between organisms allows us to

classify
clone
grow

the organisms.

(1)

(b) Complete the following sentence.

Living things can be grouped into animals, microorganisms and

(1)

(Total 4 marks)

Q9.The diagram shows a method used to grow pure cultures of a bacterium.

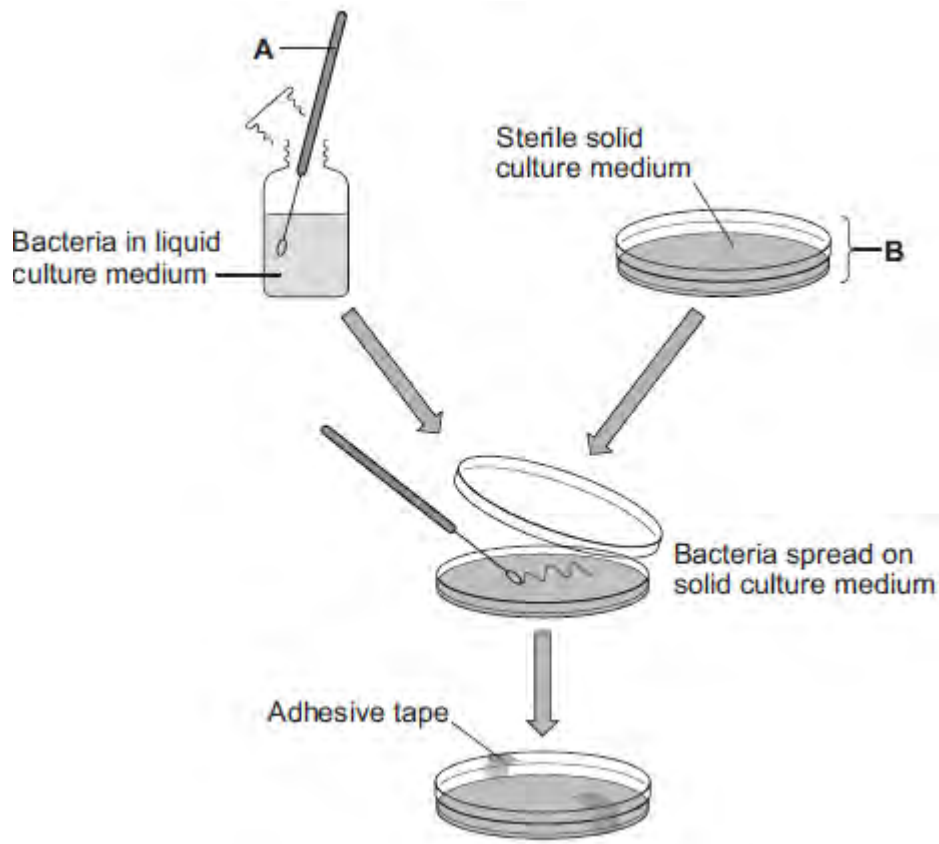

(a) Name apparatus **A** and apparatus **B**.

Apparatus **A**

Apparatus **B**

(2)

(b) (i) Why should apparatus **A** and apparatus **B** be sterilised before they are used?

.....

(1)

(ii) How should apparatus **A** be sterilised?

Tick (✓) **one** box.

Using enzymes

Using a flame

In an incubator

(1)

(iii) Adhesive tape is used to secure the lid on apparatus **B**.

Give **one** reason why the lid of apparatus **B** should be securely taped in place.

.....
.....

(1)

(c) What is the maximum temperature that should be used **in schools** to grow the bacteria in apparatus **B**?

Draw a ring around the correct answer.

10 °C

25 °C

50 °C

(1)
(Total 6 marks)

Q10. Human cells and yeast cells have some parts that are the same.

(a) The diagram shows a yeast cell.

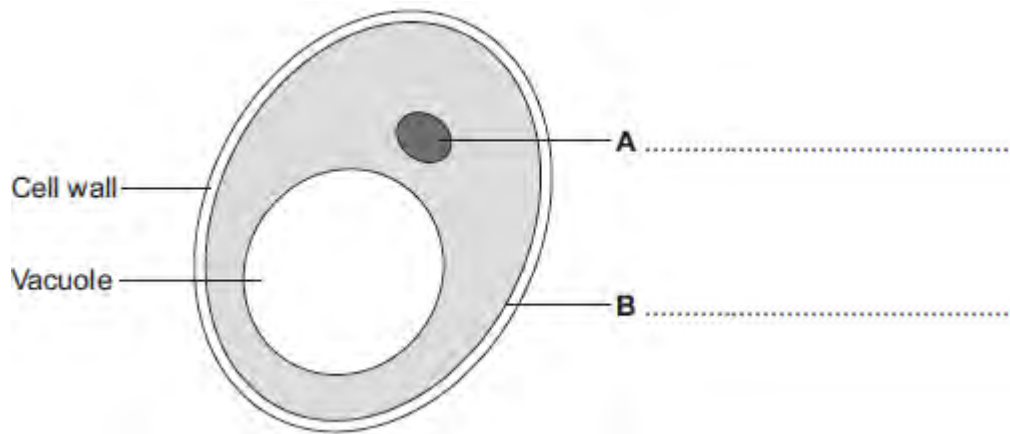

Parts **A** and **B** are found in human cells and in yeast cells. On the diagram, label parts **A** and **B**.

(2)

(b) Many types of cell can divide to form new cells.

Some cells in human skin can divide to make new skin cells.

Why do human skin cells need to divide?

.....
.....

(1)

(c) Human stem cells can develop into many different types of human cell.

(i) Use the correct answer from the box to complete the sentence.

embryos	hair	nerve cells
----------------	-------------	--------------------

Human stem cells may come from

.....

(1)

(ii) Use the correct answer from the box to complete the sentence.

cystic fibrosis	paralysis	polydactyly
------------------------	------------------	--------------------

Human stem cells can be used to treat

.....

(1)
(Total 5 marks)

- M1.**
- (a) (i) nucleus 1
 - (ii) diffusion 1

 - (b) increases / larger surface area (for diffusion) 1
ignore large surface area to volume ratio

 - (c) (i) sugar / glucose 1
accept amino acids / other named monosaccharides
 - (ii) against a concentration gradient 1
or
 from low to high concentration
 - (iii) (active transport requires) energy 1

 (from) respiration 1

 - (d) minerals / ions 1
accept named ion ignore nutrients
do not accept water

[8]

- M2.** (a) contract / shorten
ignore relax
*do **not** allow expand* 1
- to churn / move / mix food
accept peristalsis / mechanical digestion
ignore movement unqualified 1
- (b) 400
acceptable range 390-410
allow 1 mark for answer in range of 39 to 41
allow 1 mark for answer in range of 3900 to 4100 2
- (c) to transfer energy for use
allow to release / give / supply / provide energy
*do **not** allow to 'make' / produce' / 'create' energy*
allow to make ATP
ignore to store energy 1
- by (aerobic) respiration **or** from glucose
*do **not** allow anaerobic*
*energy released **for** respiration = max 1 mark* 1
- (d) (i) to make protein / enzyme
ignore 'antibody' or other named protein 1
- (ii) too small / very small
allow light microscope does not have sufficient magnification / resolution

allow ribosomes are smaller than mitochondria
ignore not sensitive enough
ignore ribosomes are transparent

1

[8]

- M3.** (a) Marks awarded for this answer will be determined by the Quality of Written Communication (QWC) as well as the standard of the scientific response. Examiners should also refer to the information in the [Marking guidance](#), and apply a 'best-fit' approach to the marking.

0 marksNo relevant content.

Level 1 (1-2 marks)There is a brief description of at least one of the stages (pre-inoculation, inoculation, post-inoculation).

Level 2 (3-4 marks)There is a simple description of at least two stages and an explanation of at least one of them.

Level 3 (5-6 marks)There is a clear description of all three stages and an explanation of at least two of them.

Examples of Biology points made in the response:

Pre-inoculation

- Petri dish and agar sterilised before use
- to kill unwanted bacteria
- inoculating loop passed through flame / sterile swab
- to sterilise / kill (other) bacteria

Inoculation

- loop/swab used to spread/streak bacterium onto agar

Allow other correct methods, eg bacterial lawns

- lid of Petri dish opened as little as possible
- to prevent microbes from air entering

Post-inoculation

- sealed with tape
- to prevent microbes from air entering
- incubate

- to allow growth of bacteria

6

- (b) (i) bacteria killed / destroyed
ignore fights / attacks / stops growth / got rid of

1

- (ii) *Might be correct*

largest area / space where no bacteria are growing
allow most bacteria killed

1

Might not be correct

(need more evidence as) D may be harmful to people / animals / surfaces

ignore ref to cost / dangerous or harmful unqualified

1

or may work differently with different bacteria

or disinfectants may be different concentrations

ignore different amounts of disinfectant unless reference to different drop size

or may not last as long

ignore take longer to work

allow reference to anomalous result or not repeated

[9]

M4. (a) any **two** from:

- only one 'chromosome'
allow one strand of DNA
- circular
allow loop
- may have plasmids
- not in a nucleus / no nucleus

2

(b) (i) any **one** from:

- London is much higher
or converse
- more variable / wider range
allow 'on average it is 5 / 6 times greater'

1

(ii) increases

Included figures must be correct

1

(iii) overall slight increase

accept 'doesn't change much'

1

variable / goes up and down

1

(c) (i) both axes correctly labelled

x = Year

y = Number of cases

1

correct points

all correct = 2 marks

1-2 errors = 1 mark

> 2 errors = 0 marks

2

suitable line of best fit

accept straight line or smooth curve

1

(ii) doesn't fit the pattern / line of best fit

1

(d) provides immunity / protection (to TB)

ignore 'stops people catching it'

ignore 'resistance'

1

prevents TB spreading

accept ref to herd immunity

1

[13]

M5.	(a)	(i)	chloroplast	1
		(ii)	cell wall	1
	(b)	(i)	osmosis <i>accept diffusion</i>	1
		(ii)	cell wall (prevents bursting)	1
	(c)	(i)	carbon dioxide <i>allow correct formula</i>	1
			glucose <i>allow sugar / starch</i>	1
		(ii)	any two from: <ul style="list-style-type: none"> • light sensitive spot detects light • tells flagellum to move towards light • more light = more photosynthesis 	2
	(d)		(cell has) larger SA:volume ratio	1
			short (diffusion) distance <i>allow correct description</i>	1

(diffusion) via cell membrane is sufficient / good enough

or

flow of water maintains concentration gradient

1
[11]

- M6. (a) (i) xylem** **1**
- (ii) water **1**
- minerals / ions / named example(s)
ignore nutrients **1**
- (b) (i) movement of (dissolved) sugar
allow additional substances, eg amino acids / correct named sugar (allow sucrose / glucose)
allow nutrients / substances / food molecules if sufficiently qualified
ignore food alone **1**
- (ii) sugars are made in the leaves **1**
- so they need to be moved to other parts of the plant for respiration / growth / storage **1**
- (c) (i) mitochondria **1**
- (ii) for movement of minerals / ions
Do not accept 'water' **1**
- against their concentration gradient

Q1.The image below shows an epithelial cell from the lining of the small intestine.

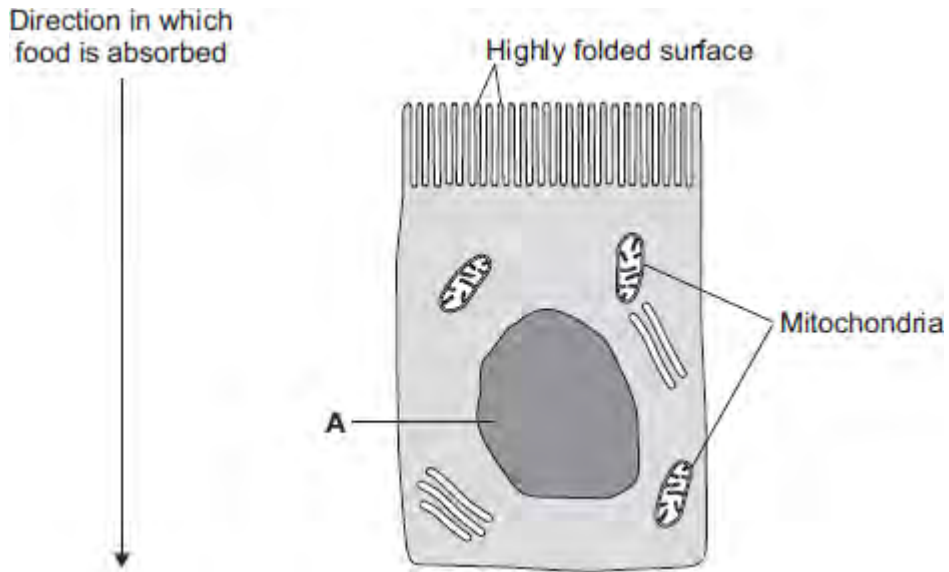

- (a) (i) In the image above, the part of the cell labelled **A** contains chromosomes.
What is the name of part **A**?

.....

(1)

- (ii) How are most soluble food molecules absorbed into the epithelial cells of the small intestine?

Draw a ring around the correct answer.

diffusion osmosis respiration

(1)

- (b) Suggest how the highly folded cell surface helps the epithelial cell to absorb soluble food.

.....
.....

(1)

- (c) Epithelial cells also carry out active transport.

(i) Name **one** food molecule absorbed into epithelial cells by active transport.

.....

(1)

(ii) Why is it necessary to absorb some food molecules by active transport?

.....

.....

(1)

(ii) Suggest why epithelial cells have many mitochondria.

.....

.....

.....

.....

(2)

(d) Some plants also carry out active transport.

Give **one** substance that plants absorb by active transport.

.....

(1)

(Total 8 marks)

Q2. The image below shows some muscle cells from the wall of the stomach, as seen through a light microscope.

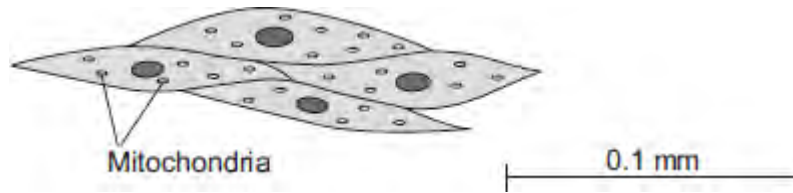

(a) Describe the function of muscle cells in the wall of the stomach.

.....

.....

.....

.....

(2)

(b) **Figure above** is highly magnified.

The scale bar in **Figure above** represents 0.1 mm.

Use a ruler to measure the length of the scale bar and then calculate the magnification of **Figure above**.

.....

.....

.....

.....

Magnification = times

(2)

(c) The muscle cells in **Figure above** contain many mitochondria.

What is the function of mitochondria?

.....

.....

.....

.....

(2)

(d) The muscle cells also contain many ribosomes. The ribosomes cannot be seen in **Figure above**.

(i) What is the function of a ribosome?

.....

.....

(1)

(ii) Suggest why the ribosomes **cannot** be seen through a light microscope.

.....

.....

(1)

(Total 8 marks)

Q3.A student is given a tube containing a liquid nutrient medium. The medium contains one type of bacterium.

- (a) *In this question you will be assessed on using good English, organising information clearly and using specialist terms where appropriate.*

The student is told to grow some of the bacteria on agar jelly in a Petri dish.

Describe how the student should prepare an uncontaminated culture of the bacterium in the Petri dish.

You should explain the reasons for each of the steps you describe.

.....

.....

.....

.....

.....

.....

.....

.....

.....

.....

.....

(6)

- (b) After the culture had been prepared, the student added one drop of each of five disinfectants, **A**, **B**, **C**, **D** and **E**, onto the culture.

The diagram shows the appearance of the Petri dish 3 days later.

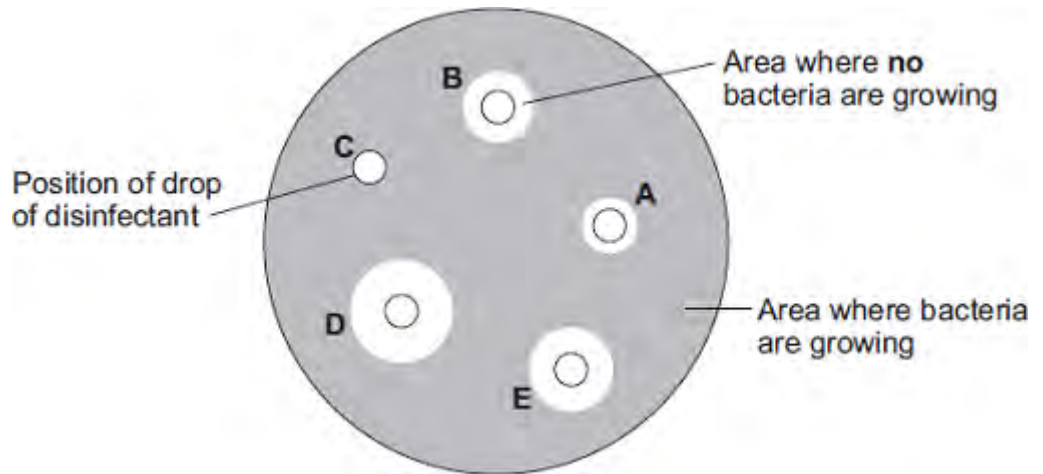

(i) There are areas on the agar jelly where **no** bacteria are growing.

Why?

.....

(1)

(ii) The student concluded that disinfectant **D** would be the best for using around the home.

Give **one** reason why the student might be correct.

.....

Give **one** reason why the student might **not** be correct.

.....

(2)

(Total 9 marks)

Q4.Some infections are caused by bacteria.

- (a) The genetic material is arranged differently in the cells of bacteria compared with animal and plant cells.

Describe **two** differences.

.....

.....

.....

.....

(2)

- (b) Tuberculosis (TB) is an infection caused by bacteria.

The table below shows the number of cases of TB in different regions of southern England from 2000–2011.

Number of cases of TB per 100 000 people

Year	London	South East	South West
2000	37	5	3
2001	36	6	4
2002	42	6	6
2003	42	7	4
2004	42	7	5
2005	49	8	5
2006	44	8	3
2007	43	8	5
2008	44	8	5
2009	44	9	6
2010	42	9	5
2011	45	10	5

(i) How does the number of cases of TB for London compare with the rest of southern England?

.....
.....
.....

(1)

(ii) Describe the pattern in the data for cases of TB in the South East.

.....
.....

(1)

(iii) Describe the pattern in the data for cases of TB in the South West.

.....
.....
.....
.....

(2)

(c) (i) On the graph paper below:

- plot the number of cases of TB in **London**
- label both the axes on the graph
- draw a line of best fit.

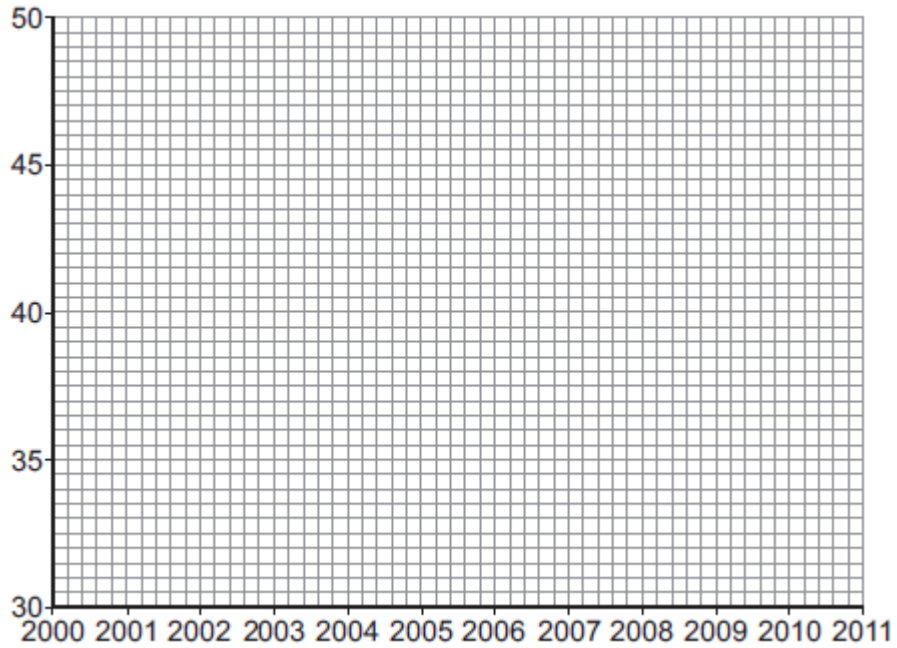

(4)

(ii) Suggest why a student thought the value for 2005 in London was anomalous.

.....

(1)

(d) People can be vaccinated against TB.

Suggest how a vaccination programme would reduce the number of people with TB.

Details of how a vaccine works are **not** required.

.....

(2)

(Total 13 marks)

Q5.The diagram below shows a single-celled alga which lives in fresh water.

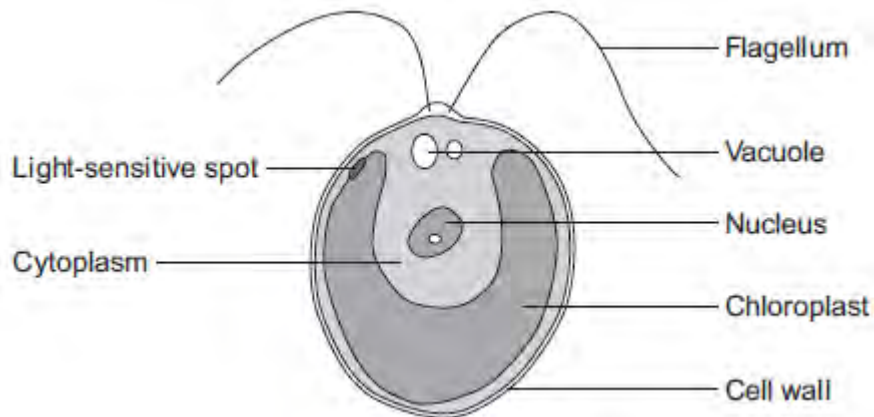

(a) Which part of the cell labelled above:

(i) traps light for photosynthesis

.....

(1)

(ii) is made of cellulose?

.....

(1)

(b) In the freshwater environment water enters the algal cell.

(i) What is the name of the process by which water moves into cells?

.....

(1)

(ii) Give the reason why the algal cell does not burst.

.....

.....

(1)

- (c) (i) The alga can photosynthesise.

Complete the **word** equation for photosynthesis.

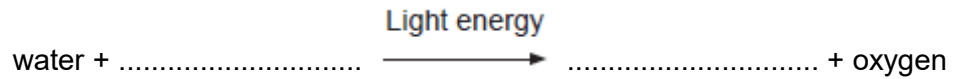

(2)

- (ii) The flagellum helps the cell to move through water. Scientists think that the flagellum and the light-sensitive spot work together to increase photosynthesis.

Suggest how this might happen.

.....
.....
.....
.....

(2)

- (d) Multicellular organisms often have complex structures, such as lungs, for gas exchange.

Explain why single-celled organisms, like algae, do **not** need complex structures for gas exchange.

.....
.....
.....
.....
.....
.....

(3)

(Total 11 marks)

Q6.The diagram below shows a cross-section of a plant root. The transport tissues are labelled.

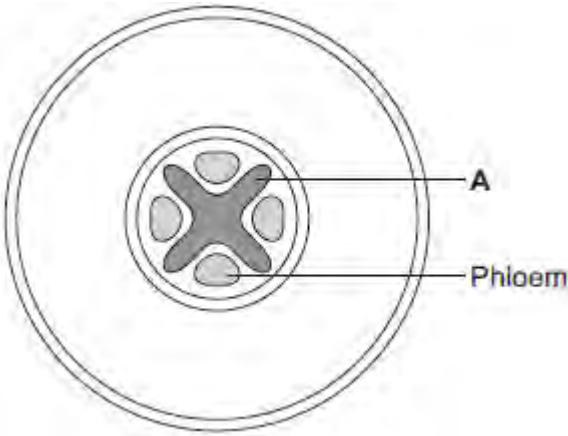

(a) (i) What is tissue **A**?

Draw a ring around the correct answer.

- cuticle**
- epidermis**
- xylem**

(1)

(ii) Name **two** substances transported by tissue **A**.

1

2

(2)

(b) Phloem is involved in a process called translocation.

(i) What is translocation?

.....

(1)

(ii) Explain why translocation is important to plants.

.....
.....
.....
.....

(2)

(c) Plants must use active transport to move some substances from the soil into root hair cells.

(i) Active transport needs energy.

Which part of the cell releases most of this energy?

Tick (✓) **one** box.

mitochondria

nucleus

ribosome

(1)

(ii) Explain why active transport is necessary in root hair cells.

.....
.....
.....
.....
.....
.....

(2)

(Total 9 marks)

- M1. (a) C 1
- (b) cytoplasm **and** cell membrane dividing
accept cytokinesis for 1 mark 1
- to form two identical daughter cells 1
- (c) stage 4 1
- only one cell seen in this stage 1
- (d) $(4 / 36) \times 16 \times 60$ 1
- 107 / 106.7 1
- 110 (minutes)
allow 110 (minutes) with no working shown for 3 marks 1
- (e) binary fission
do not accept mitosis 1
- (f) shortage of nutrients / oxygen

1

so cells die
or
death rate = rate of cell division

1

[11]

M2. (a) hold cells together **or** prevent flow of cells **or** trap cells 1

(b) 12500

if correct answer, ignore working / lack of working

$$\frac{100}{0.008} \text{ for 1 mark}$$

ignore any units

2

(c) (i) size RBC approximately same size capillary **or**
no room for more than one cell **or**
only one can fit **or**
RBC is too big

allow use of numbers

*do **not** accept capillaries are narrow*

1

(ii) more oxygen released (to tissues) **or**
more oxygen taken up (from lungs)

1

and any **two** from:

- slows flow **or** more time available
- shorter distance (for exchange) **or** close to cells / capillary wall
- more surface area exposed

2

[7]

M3. (a) any **two** from:

- sterilise / kill microorganisms
ignore 'cleaning' / 'disinfect'
ignore 'germs'
- method of sterilisation eg apparatus / media sterilised in oven / autoclave
allow pressure cooker / boiling water
- pass flask mouth / pipette tip / loop / test tube mouth through flame
- work near a flame
- minimise opening of flask / test tube **or** hold non-vertical
*allow idea of sealing / covering **or** prevent entry of air*

2

(b) any **two** from:

- temperature
ignore references to time / type of bacterium
- concentration / amount of nutrients / ions
- type of nutrient
- volume / amount of solution
- amount of bacteria added
- agitation **or** amount of oxygen

2

(c) (i) 7.5

accept in range 7.4 – 7.6

1

(ii) use more pH values around / close to pH 7.5 / between 7 and 8

1

[6]

- M4.** (a) **A** cytoplasm
in this order only 1
- B** (cell) membrane
*do **not** accept (cell) wall* 1
- (b) (i) synapse 1
- (ii) (as) chemical
accept neurotransmitter or named
ignore references to how the chemical is passed
*do **not** accept electrical* 1
- (c) (from light-sensitive cell to connecting neurone) to sensory neurone
ignore references to synapses accept 'nerve cell' for
neuron(e) throughout penalise 'nerve' for neurone once only 1
- (sensory neurone) to brain / CNS
allow (sensory neurone) to relay neurone / spinal cord 1
- (brain / CNS) to motor neurone
allow (relay neurone / spinal cord) to motor neurone 1
- (motor neurone) to (eyelid) muscle
ignore effector 1

[8]

- M5.** (a) (i) diffusion is down the concentration gradient
for a description of diffusion
ignore along / across gradients 1
- to enter must go up / against the concentration gradient
accept by diffusion ions would leave the root
- or**
- concentration higher in the root / plant
- or**
- concentration lower in the soil 1
- (ii) active transport
allow active uptake 1
- (b) (i) (root hairs →) large surface / area 1
- (ii) (aerobic) respiration
do not allow anaerobic 1
- releases / supplies / provides / gives energy
accept make ATP (for active transport)
do not allow 'makes / produces / creates' energy 1
- (iii) starch is energy source / store (for active transport)
allow starch can be used in respiration
do not allow 'makes / produces / creates' energy 1

M6.

(a) both parents **Aa**

*accept other upper and lower case letter without key **or** symbols with a key*

allow as gametes shown in Punnett square

1

aa in offspring correctly derived from parents

or

aa correctly derived from the parents given

ignore other offspring / gametes

for this mark parents do not have to be correct

1

offspring **aa** identified as having cystic fibrosis

*may be the only offspring shown **or** circled / highlighted / described*

1

(b) (i) any **one** from:

accept converse if clear, eg if you (only) took one it might have cystic fibrosis / might not be fertilised

- (more) sure / greater chance of healthy / non-cystic fibrosis egg / embryo / child

accept some may have the allele

reference to 'suitable / good embryo' is insufficient

- greater chance of fertilisation

1

(ii) **advantages**

to gain 3 marks both advantage(s) and disadvantage(s) must be given

max 3

any **two** from:

ignore references to abortion unless qualified by later screening

- greater / certain chance of having child / embryo without cystic fibrosis / healthy
- child with cystic fibrosis difficult / expensive to bring up
- cystic fibrosis (gene / allele) not passed on to future generations

disadvantages

any **two** from:

- operation dangers / named eg infection
ignore risk unqualified
- ethical or religious issues linked with killing embryos
*accept wrong / cruel to embryos accept right to life argument
ignore embryos are destroyed*
- (high) cost of procedure
- possible damage to embryo (during testing for cystic fibrosis / operation)

plus

conclusion

a statement that implies a qualified value judgement
eg it is right because the child will (probably) not have cystic fibrosis even though it is expensive

or

eg it is wrong because embryos are killed despite a greater chance of having a healthy baby

***note:** the conclusion mark cannot be given unless a reasonable attempt to give both an advantage and a disadvantage is made*

*do **not** award the mark if the conclusion only states that advantages outweigh the disadvantages*

1

(c) any **three** from:

- osmosis / diffusion
*do **not** accept movement of ions / solution by osmosis / diffusion*

- more concentrated solution outside cell / in mucus
assume concentration is concentration of solute unless answer indicates otherwise or accept correct description of 'water concentration'
- water moves from dilute to more concentrated solution
allow correct references to movement of water in relation to concentration gradient
- partially permeable membrane (of cell)
allow semi / selectively permeable

3

[11]

- M7.** (a) (i) mitochondrion / mitochondria
must be phonetically correct 1
- (ii) carbon dioxide / CO₂ 1
- water / H₂O 1
- in either order*
*accept CO₂ but **not** CO²*
*accept H₂O **or** HOH but not H²O*
- (iii) diffusion 1
- high to low concentration
allow down a concentration gradient 1
- through (cell) membrane **or** through cytoplasm
*do **not** accept cell wall* 1
- (b) ribosomes make proteins / enzymes 1
- using amino acids 1
- part A / mitochondria provide the energy for the process
allow ATP
*do **not** accept produce or make energy* 1

[9]

Q1.Figure 1 shows photographs of some animal cells at different stages during the cell cycle.

Figure 1

A

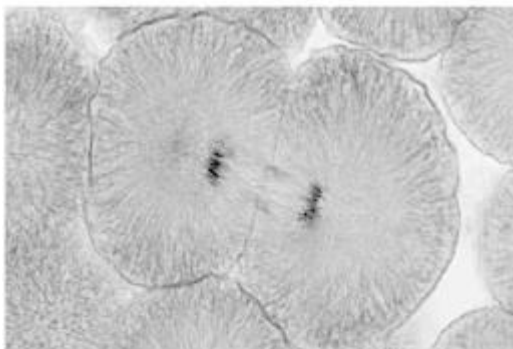

B

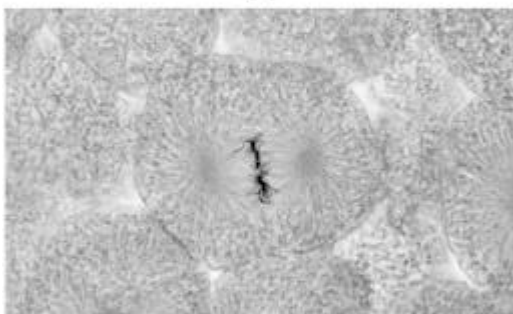

C

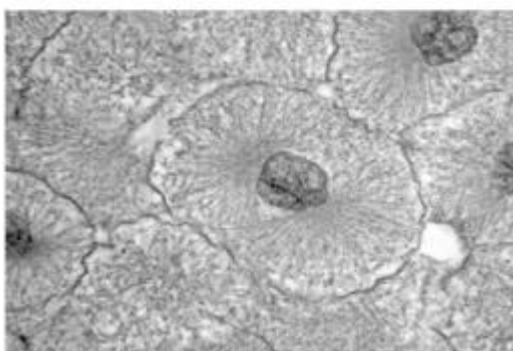

A © Ed Reschke/Photolibary/Getty Images
B © Ed Reschke/Oxford Scientific/Getty Images
C © Ed Reschke/Photolibary/Getty Images

(a) Which photograph in **Figure 1** shows a cell that is **not** going through mitosis?

Tick **one** box.

A **B** **C**

(1)

(b) Describe what is happening in photograph A.

.....
.....
.....
.....
.....

(2)

(c) A student wanted to find out more about the cell cycle.

The student made a slide of an onion root tip.

She counted the number of cells in each stage of the cell cycle in one field of view.

The table below shows the results.

	Stages in the cell cycle					
	Non-dividing cells	Stage 1	Stage 2	Stage 3	Stage 4	Total
Number of cells	20	9	4	2	1	36

Each stage of the cell cycle takes a different amount of time.

Which stage is the fastest in the cell cycle?

Give a reason for your answer.

Stage

Reason

.....

(2)

(d) The cell cycle in an onion root tip cell takes 16 hours.

Calculate the length of time **Stage 2** lasts in a typical cell.

Give your answer to 2 significant figures.

.....
.....
.....
.....

Time in **Stage 2** = minutes

(3)

(e) Bacteria such as *Escherichia coli* undergo cell division similar to mitosis.

Figure 2 shows a growth curve for *E. coli* grown in a nutrient broth.

Figure 2

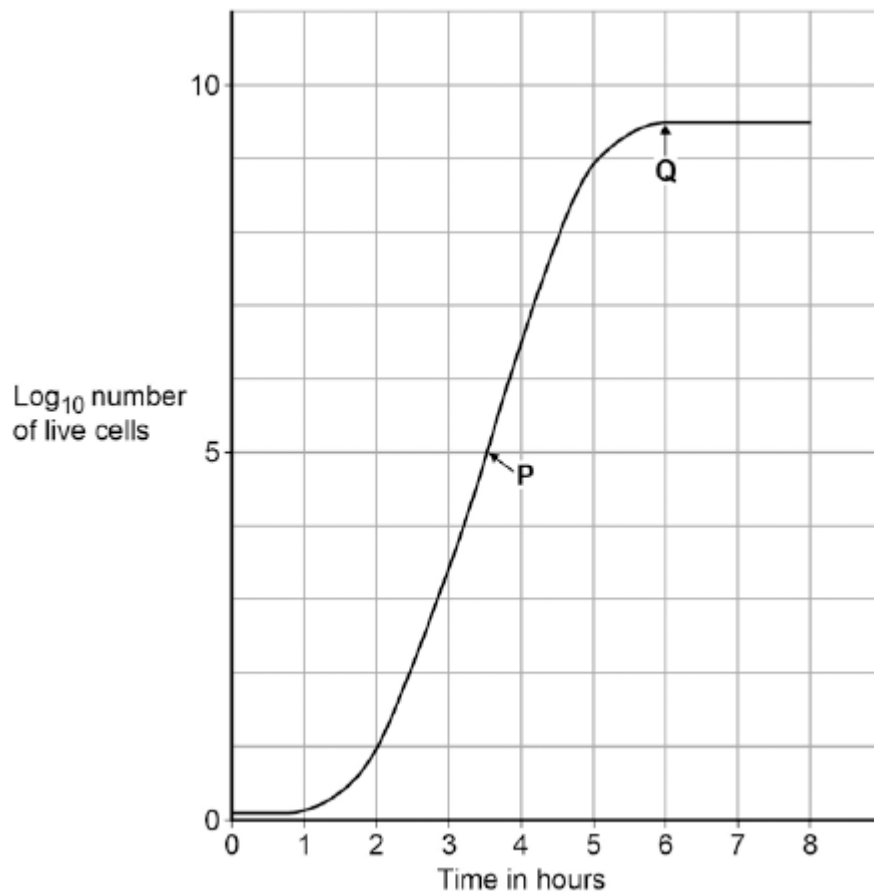

What type of cell division causes the change in number of *E. coli* cells at **P**?

.....

(1)

(f) Suggest why the number of cells levels out at **Q**.

.....
.....
.....
.....
.....
.....
.....

(2)

(Total 11 marks)

Q2. The photograph shows a red blood cell in part of a blood clot. The fibres labelled **X** are produced in the early stages of the clotting process.

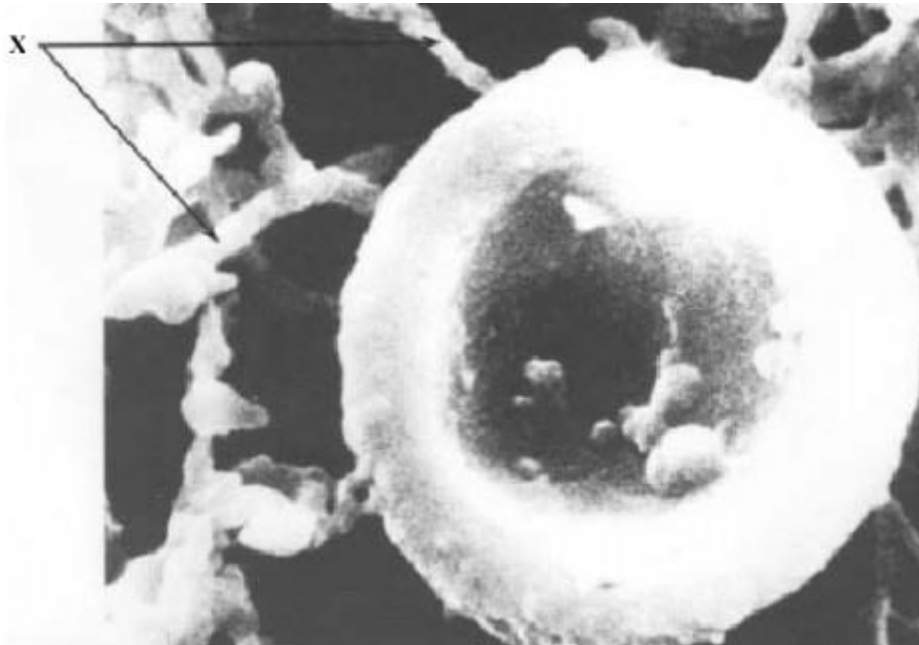

(a) Suggest how the fibres labelled **X** help in blood clot formation.

..... (1)

(b) The average diameter of a real red blood cell is 0.008 millimetres.
On the photograph, the diameter of the red blood cell is 100 millimetres.

Use the formula to calculate the magnification of the photograph.

$$\text{Diameter on photograph} = \text{Real diameter} \times \text{Magnification}$$

.....

$$\text{Magnification} = \dots\dots\dots$$

(2)

(c) Some blood capillaries have an internal diameter of approximately 0.01 millimetres.

(i) Use information given in part (b) to explain why only one red blood cell at a time can pass through a capillary.

.....

(1)

(ii) Explain the advantages of red blood cells passing through a capillary one at a time.

.....

.....

.....

.....

.....

.....

(3)

(Total 7 marks)

Q3. Some students investigated the effect of pH on the growth of one species of bacterium.

They transferred samples of bacteria from a culture of this species to each of eight flasks. Each flask contained a solution of nutrients but at a different pH.

After 24 hours, the students measured the amount of bacterial growth.

(a) It was important that the flasks in which the bacteria grew were not contaminated with other microorganisms.

Describe **two** precautions the students should have taken to prevent this contamination.

- 1
-
- 2
-

(2)

(b) To see the effect of pH on the growth of the bacteria, other conditions should be kept constant.

Suggest **two** conditions which should have been kept constant for all eight flasks.

- 1
- 2

(2)

(c) The graph shows the results of the investigation.

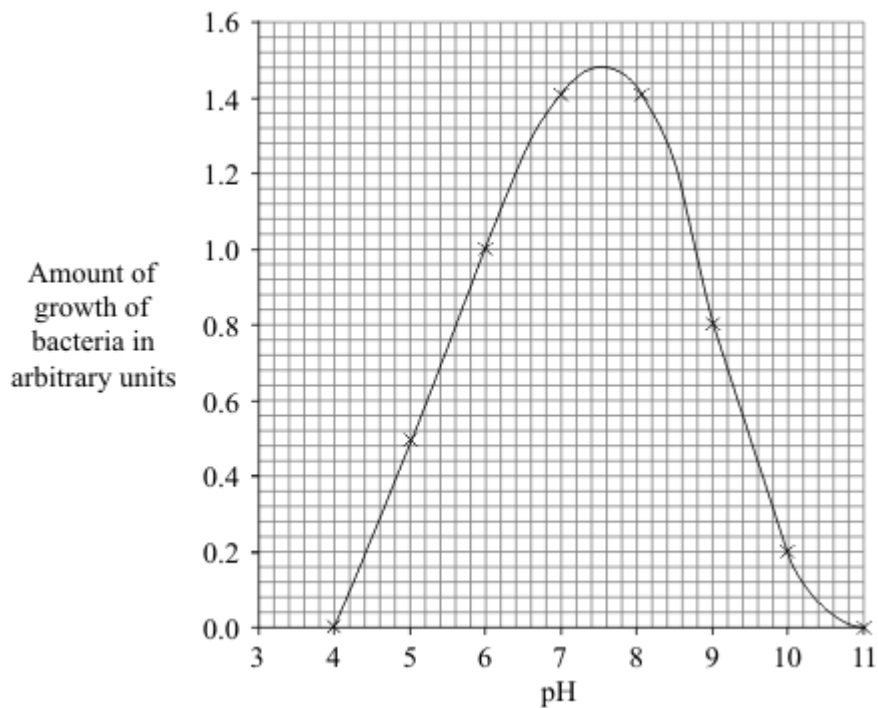

The students wanted to find the best pH for the growth of this species of bacterium.

- (i) Use the graph to estimate the pH at which the bacteria would grow best.

pH

(1)

- (ii) What could the students do to find a more accurate value for the best pH for growth of the bacteria?

.....

(1)

(Total 6 marks)

Q4. Diagram 1 shows cells from the light-sensitive layer in the eye.

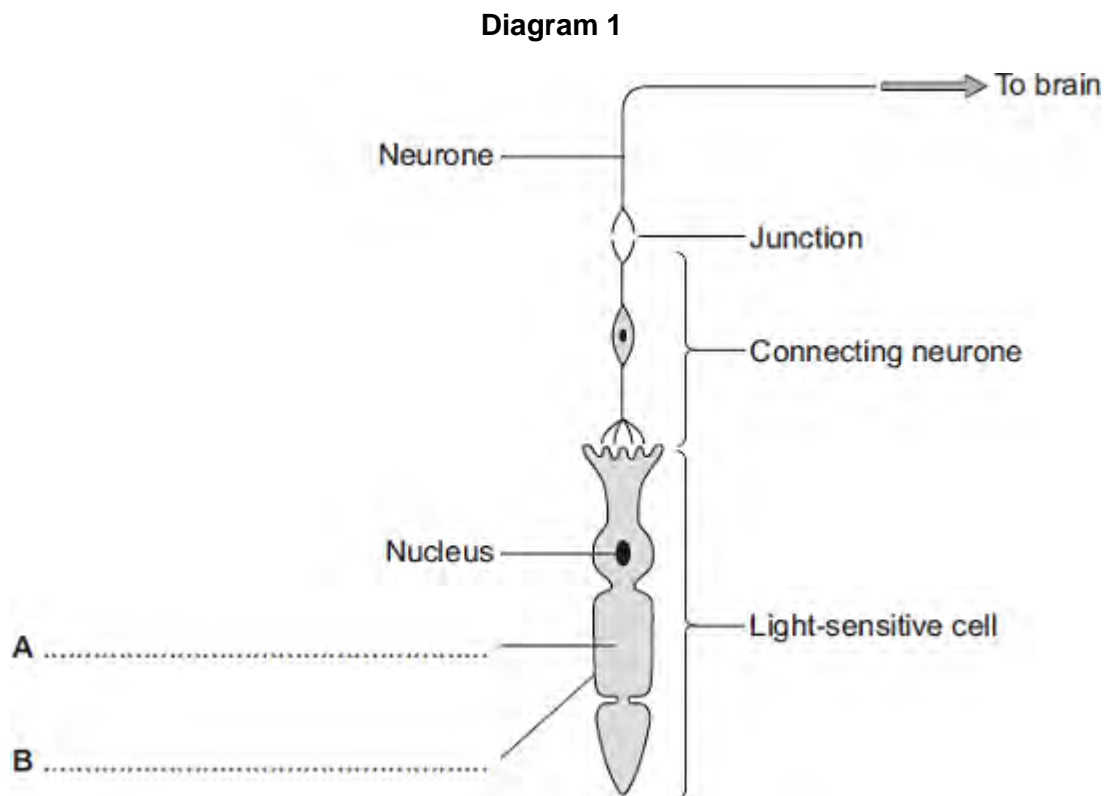

(a) On **Diagram 1**, add labels to name part **A** and part **B** of the light-sensitive cell. (2)

(b) There is a junction between the connecting neurone and the neurone carrying the impulse to the brain.

(i) What name is given to the junction?

.....

(1)

(ii) In what form is information passed across the junction?

.....

.....

(1)

(c) Diagram 2 shows a bee flying towards a man's eye.

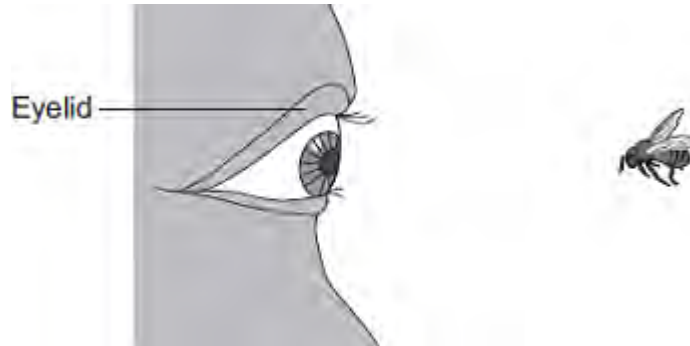

In the *blink reflex* , light from the bee reaches the light-sensitive cell in the eye. The muscles in the eyelid shut the man's eye before the bee hits the eye.

Describe the pathway taken by the nerve impulse in the *blink reflex*.

.....

.....

.....

.....

.....

.....

.....

.....

.....

.....

.....

(4)
(Total 8 marks)

Q5. The table shows the concentrations of three mineral ions in the roots of a plant and in the water in the surrounding soil.

Mineral ion	Concentration in millimoles per kilogram	
	Plant root	Soil
Calcium	120	2.0
Magnesium	80	3.1
Potassium	250	1.2

(a) (i) The plant roots could **not** have absorbed these mineral ions by diffusion.

Explain why.

.....

.....

.....

.....

(2)

(ii) Name the process by which the plant roots absorb mineral ions.

.....

(1)

(b) How do the following features of plant roots help the plant to absorb mineral ions from the soil?

(i) A plant root has thousands of root hairs.

.....

.....

(1)

(ii) A root hair cell contains many mitochondria.

.....
.....
.....
.....

(2)

(iii) Many of the cells in the root store starch.

.....
.....

(1)

(Total 7 marks)

- Q6.(a)** Mr and Mrs Smith both have a history of cystic fibrosis in their families.
Neither of them has cystic fibrosis.
Mr and Mrs Smith are concerned that they may have a child with cystic fibrosis.
- Use a genetic diagram to show how they could have a child with cystic fibrosis.
- Use the symbol **A** for the dominant allele and the symbol **a** for the recessive allele.

(3)

- (b) Mr and Mrs Smith decided to visit a genetic counsellor who discussed embryo screening.

Read the information which they received from the genetic counsellor.

- Five eggs will be removed from Mrs Smith's ovary while she is under an anaesthetic.
- The eggs will be fertilised in a dish using Mr Smith's sperm cells.
- The embryos will be grown in the dish until each embryo has about thirty cells.
- One cell will be removed from each embryo and tested for cystic fibrosis.
- A suitable embryo will be placed into Mrs Smith's uterus and she may become pregnant.
- Any unsuitable embryos will be destroyed.

- (i) Suggest why it is helpful to take five eggs from the ovary and not just one egg.

.....
.....

(1)

- (ii) Evaluate the use of embryo screening in this case.
Remember to give a conclusion to your evaluation.

.....
.....
.....
.....
.....
.....
.....
.....
.....
.....
.....

(4)

- (c) In someone who has cystic fibrosis the person's mucus becomes thick.

The diagram shows how, in a healthy person, cells at the lung surface move chloride ions into the mucus surrounding the air passages.

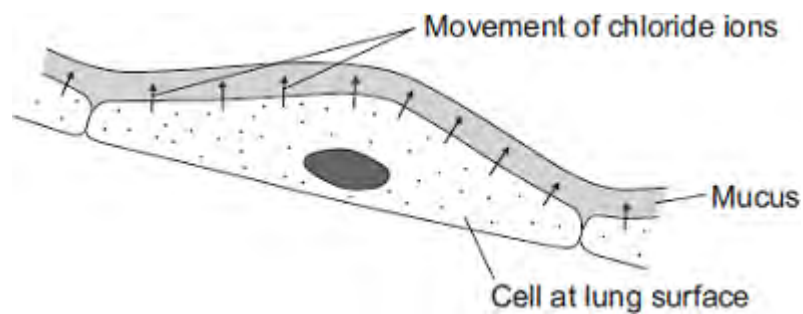

The movement of chloride ions causes water to pass out of the cells into the mucus.

Explain why.

.....

.....

.....

.....

.....

.....

.....

.....

(3)
(Total 11 marks)

Q7. Diagram 1 shows a cell from the pancreas.

Diagram 2 shows part of the cell seen under an electron microscope.

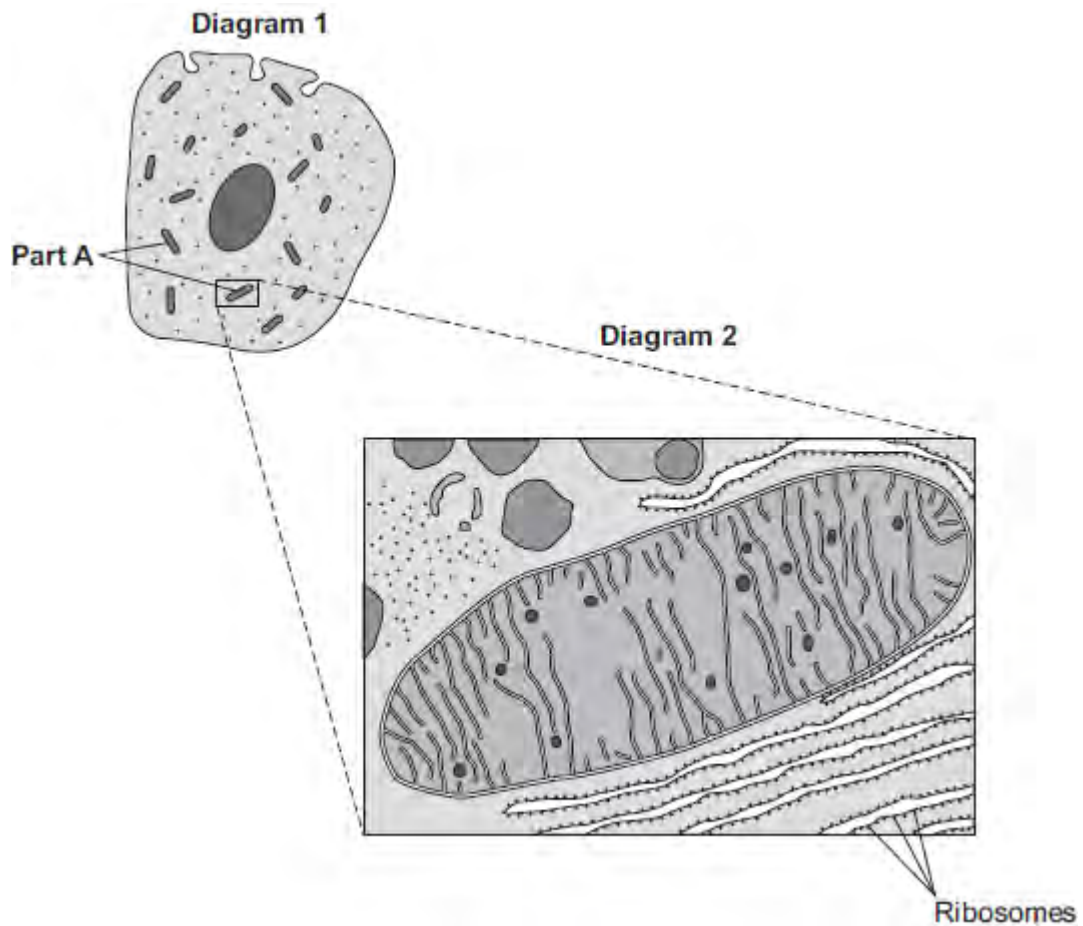

Part **A** is where most of the reactions of aerobic respiration happen.

(a) (i) Name part **A**.

.....

(1)

(ii) Complete the equation for aerobic respiration.

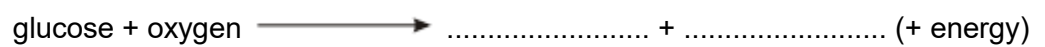

(2)

(iii) Part **A** uses oxygen.

Explain how oxygen passes from the blood to part **A**.

.....

.....

.....

.....

.....

.....

.....

.....

.....

(3)

(b) The pancreas cell makes enzymes.

Enzymes are proteins.

Describe how the ribosomes and part **A** help the cell to make enzymes.

.....

.....

.....

.....

.....

.....

.....

.....

(3)

(Total 9 marks)

M1.(a) (i) diffusion
apply list principle

1

(ii) **A**
apply list principle

1

(b) (i) osmosis
apply list principle

1

(ii) **R**
apply list principle

1

[4]

M2. (a) (i) capillary

1

(ii) diffusion

1

(iii)

Carbon dioxide	low(er)	high(er)
----------------	---------	----------

1

Oxygen	high(er)	low(er)
--------	----------	---------

1 mark for each correct row

1

(b) (i) red blood cells

1

(ii) haemoglobin

1

[6]

M3.(a) xylem and phloem

either order

allow words ringed in box

allow mis-spelling if unambiguous

1

(b) (i) movement / spreading out of particles / molecules / ions / atoms

ignore names of substances / 'gases'

1

from high to low concentration

accept down concentration gradient

ignore 'along' / 'across' gradient

ignore 'with' gradient

1

(ii) oxygen / water (vapour)

allow O₂ / O₂

ignore O² / O

allow H₂O / H₂O

ignore H²O

1

[4]

M4.(a)	300	1
(b)	suitable scale on y-axis	1
	label y-axis	1
	4 bars drawn correctly <i>allow 1 mark for 3 correct bars</i>	2
(c)	increases from 50 to 500	1
	then decreases from 500 to 0	1
(d)	carbohydrates broken down / digested into sugars	1
	broken down by carbohydrase or amylase	1
(e)	absorption of glucose	1
	into blood	1

by active transport
allow diffusion

1
[12]

M5.(a) (i) A = nucleus 1

B = (cell) membrane 1

(ii) any **two** from:
ignore shape

- no (cell) wall
- no (large / permanent) vacuole
- no chloroplasts / chlorophyll

2

(b) because high to low oxygen / concentration **or** down gradient
allow 'more / a lot of oxygen molecules outside'
ignore along / across gradient

1

(c) a tissue 1

[6]

M6.(a) osmosis 1

partially permeable 1

(b) (i) any **two** from:
allow correct answers in terms of A

- vacuole is small(er)
- cytoplasm has shrunk
allow cytoplasm is smaller
- gap between cytoplasm and cell wall
- cell wall curves inwards
allow cell B is flaccid or cell A is turgid
- the (cell) membrane has moved away from the wall

2

(ii) any **one** from:

- water will move / diffuse in
- (cells) will swell
- (cells) will burst
ignore turgid

1

(c) villi give the small intestines a large surface area 1

villi have many blood capillaries 1

[7]

- M7.(a)** (i) water / H₂O
accept oxygen
allow H₂O
*do **not** allow H^oO or H2O* 1
- (ii) the mineral ions are absorbed by active transport 1
the absorption of mineral ions needs energy 1
- (iii) have (many root) hairs 1
(which) give a large surface area (for absorption) 1
- (b) carbon dioxide in
or
oxygen out
or
control water loss
accept gas exchange
ignore gases in and out
ignore gain / lose water 1
- (c) (i) guard cells 1
- (ii) (stomata are) closed
allow there is no gap / space 1
- (iii) plant will wilt / droop
ignore die 1

[9]

- M8.(a)** (i) alveoli / alveolus
allow air sacs
allow phonetic spelling 1
- (ii) any **one** from:
 • protection (of lungs / heart)
 • help you breathe / inflate lungs. 1
- (b) (i) diffusion 1
- (ii) capillaries 1
- (iii) any **two** from:
 • (have many) alveoli
allow air sacs
 • large surface / area
 • thin (exchange) surface **or** short diffusion pathway
accept only one / two cell(s) thick
 • good blood supply / many capillaries
allow (kept) ventilated or maintained concentration gradient. 2

[6]

Q1.Substances can move into and out of cells.

- (a) (i) How does oxygen move into and out of cells?

Draw a ring around **one** answer.

diffusion

digestion

photosynthesis

(1)

- (ii) **Diagram 1** shows the percentage concentration of oxygen in three cells, **A**, **B** and **C**.

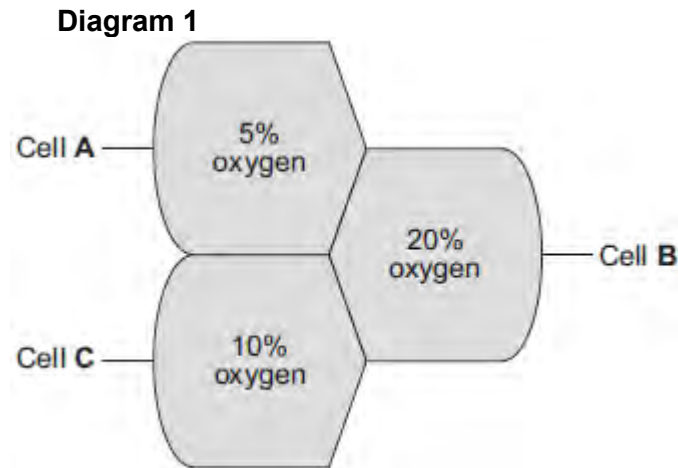

Oxygen can move from cell to cell.

Into which cell, **A**, **B** or **C**, will oxygen move the fastest?

(1)

- (b) (i) How does water move into and out of cells?

Draw a ring around **one** answer.

breathing

osmosis

respiration

(1)

- (ii) Differences in the concentration of sugars in cells cause water to move into or out of cells at different rates.

Diagram 2 shows three different cells, **P**, **Q** and **R**.

The information shows the percentage concentration of sugar solution in cells **P**, **Q** and **R**.

Diagram 2

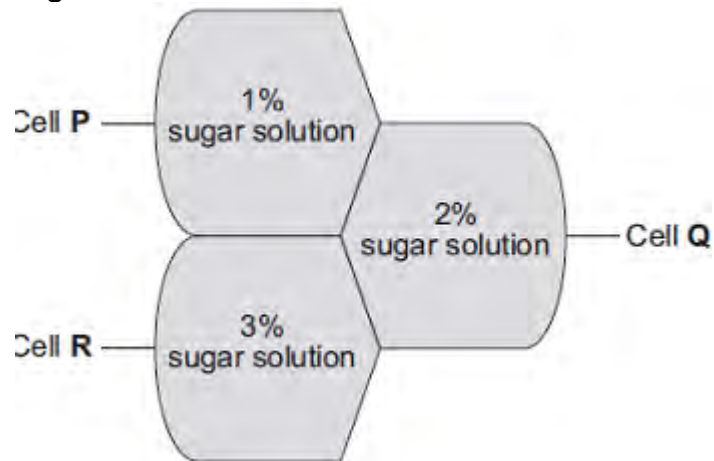

Water can move from cell to cell.

Into which cell, **P**, **Q** or **R**, will water move the fastest?

(1)
(Total 4 marks)

Q2. The diagram shows an alveolus and a blood vessel in the lung.

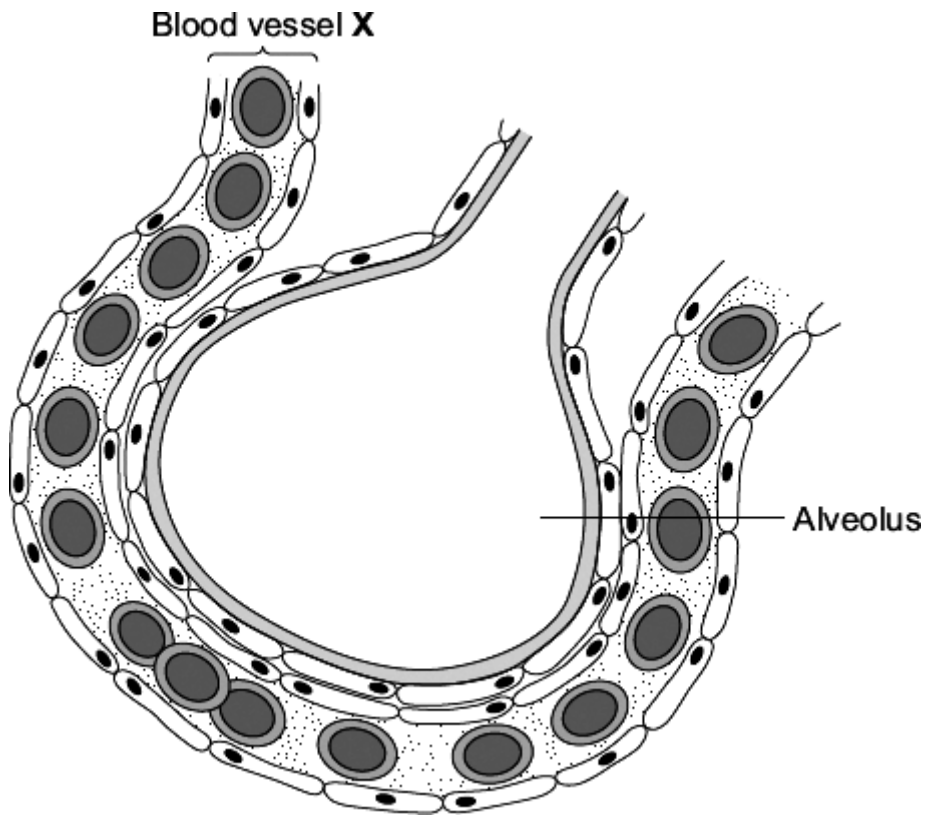

(a) Draw a ring around the correct answer to complete each sentence.

(i) Blood vessel X is

an artery.
a capillary.
a vein.

(1)

(ii) Gases pass across the wall of the alveolus by

diffusion.
evaporation.
fermentation.

(1)

- (iii) The table compares the concentrations of some gases in inhaled air and exhaled air.

Complete the table.

Write 'lower' or 'higher' in each box.

One line has been completed for you as an example.

Gas	Concentration	
	Inhaled air	Exhaled air
Water vapour	lower	higher
Carbon dioxide		
Oxygen		

(2)

- (b) Draw a ring around the correct answer to complete each sentence.

- (i) Oxygen is carried in the blood mainly in

blood plasma.
red blood cells.
white blood cells.

(1)

- (ii) In the blood, the oxygen combines with

carbon dioxide.
haemoglobin.
urea.

(1)
(Total 6 marks)

Q3. The diagram shows a section through a plant leaf.

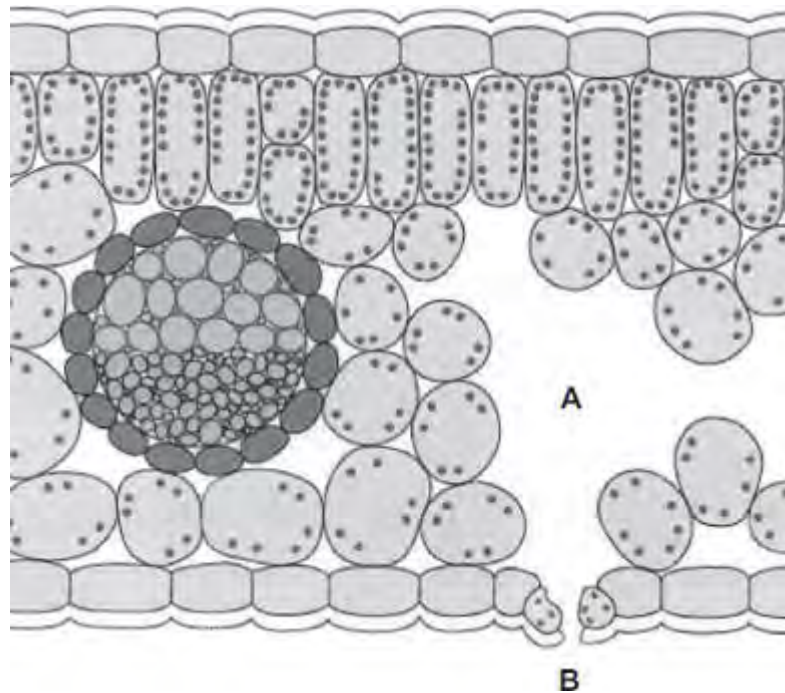

(a) Use words from the box to name **two** tissues in the leaf that transport substances around the plant.

epidermis	mesophyll	phloem	xylem
-----------	-----------	--------	-------

..... and

(1)

(b) Gases *diffuse* between the leaf and the surrounding air.

(i) What is *diffusion*?

.....

(2)

- (ii) Name **one** gas that will diffuse from point **A** to point **B** on the diagram on a sunny day.

.....

(1)
(Total 4 marks)

Q4.After a meal rich in carbohydrates, the concentration of glucose in the small intestine changes.

The table below shows the concentration of glucose at different distances along the small intestine.

Distance along the small intestine in cm	Concentration of glucose in mol dm ⁻³
100	50
300	500
500	250
700	0

- (a) At what distance along the small intestine is the glucose concentration highest?

..... cm

(1)

- (b) Use the data in the table to plot a bar chart on the graph below.

- Label the y-axis.
- Choose a suitable scale.

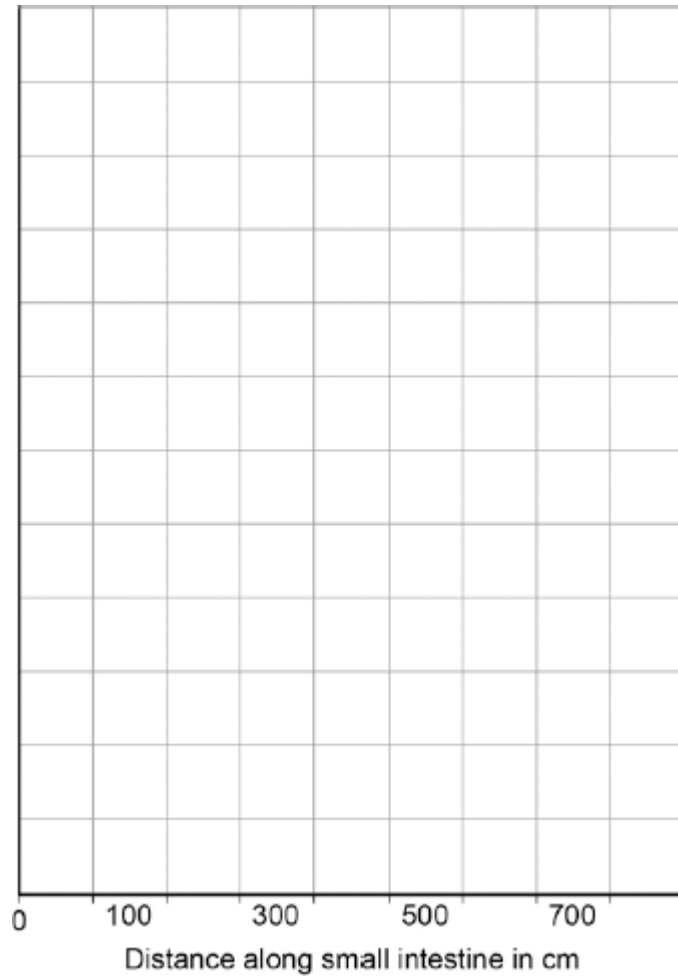

(4)

(c) Look at the graph above.

Describe how the concentration of glucose changes as distance increases along the small intestine.

.....

.....

.....

.....

(2)

(d) Explain why the concentration of glucose in the small intestine changes between 100 cm and 300 cm.

.....
.....
.....
.....
.....
.....

(2)

- (e) Explain why the concentration of glucose in the small intestine changes between 300 cm and 700 cm.

.....
.....
.....
.....
.....
.....
.....
.....

(3)

(Total 12 marks)

Q5.The diagram shows a cell.

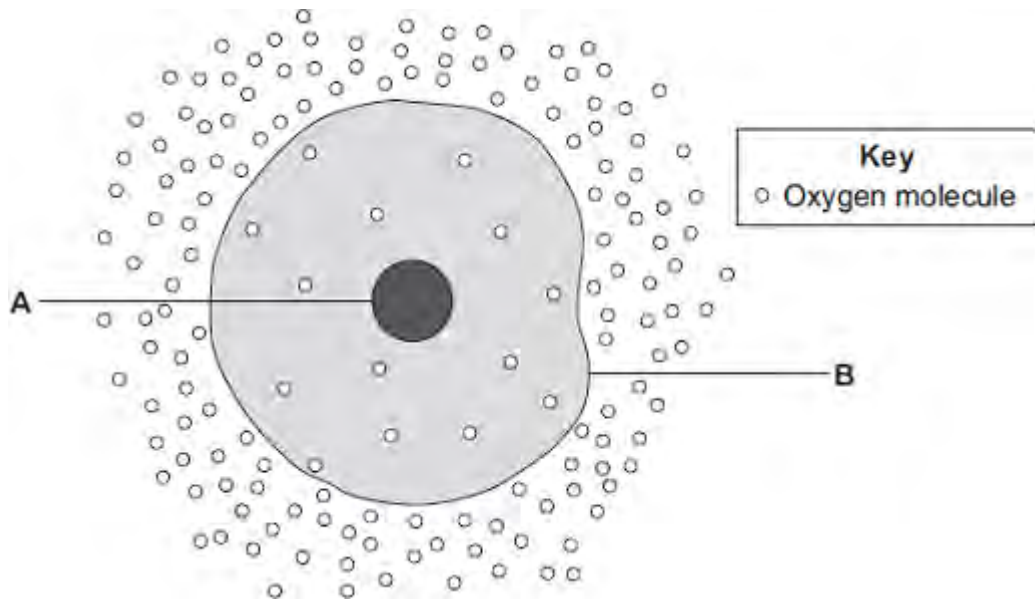

(a) (i) Use words from the box to name the structures labelled **A** and **B** .

cell membrane	chloroplast	cytoplasm	nucleus
---------------	-------------	-----------	---------

A

B

(2)

(ii) The cell in the diagram is an animal cell.

How can you tell it is an animal cell and **not** a plant cell?

Give **two** reasons.

1

.....

2

.....

(2)

(b) Oxygen will diffuse into the cell in the diagram.

Why?

Use information from the diagram.

.....
.....

(1)

(c) The cell shown in the diagram is usually found with similar cells.

Draw a ring around the correct answer to complete the sentence.

Scientists call a group of similar cells

an organ.

a system.

a tissue.

(1)
(Total 6 marks)

Q6. Substances can move into cells and out of cells.

(a) Draw a ring around the correct answer to complete each sentence.

Water moves into cells and out of cells by

- active transport.
- osmosis.
- reabsorption.

The water moves through a

- freely permeable
- non-permeable
- partially permeable

membrane.

(2)

(b) Students put plant cells into two different strengths of sugar solutions, **A** and **B**.

The diagram below shows what the cells looked like after 1 hour.

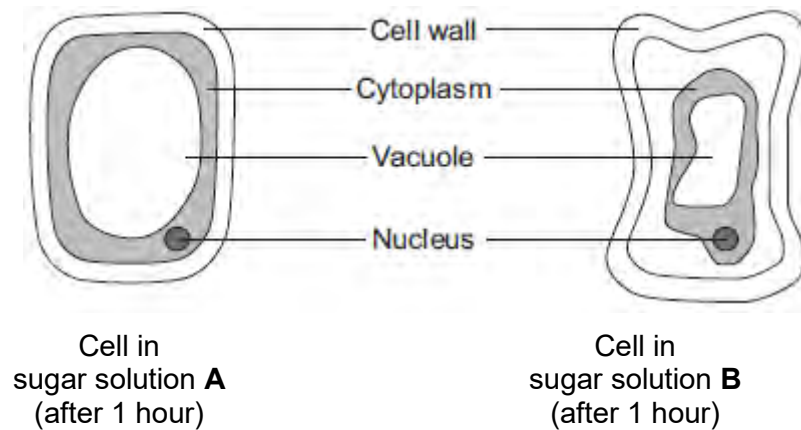

(i) Describe **two** ways in which the cell in sugar solution **B** is different from the cell in sugar solution **A**.

- 1
-
- 2
-

(2)

(ii) A student put red blood cells into water.

Suggest what would happen to the cells.

.....
.....
.....

(1)

(c) In the human body, glucose is absorbed into the blood from the small intestine.

The small intestine contains many villi.

Which **two** of the following help the absorption of glucose in the small intestine?

Tick (✓) **two** boxes.

Villi have a cell wall.

Villi are covered in thick mucus.

Villi give the small intestine a large surface area.

Villi have many blood capillaries.

(2)
(Total 7 marks)

Q7.Plants need different substances to survive. **Figure 1** shows the roots of a plant.

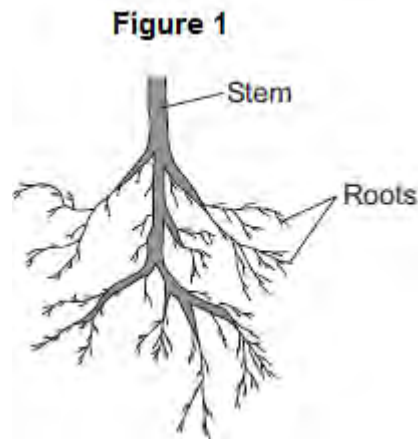

- (a) (i) Mineral ions are absorbed through the roots.

Name **one** other substance absorbed through the roots.

.....

(1)

- (ii) The plant in **Figure 1** has a higher concentration of mineral ions in the cells of its roots than the concentration of mineral ions in the soil.

Which **two** statements correctly describe the absorption of mineral ions into the plant's roots?

Tick (✓) **two** boxes.

The mineral ions are absorbed by active transport.

The mineral ions are absorbed by diffusion.

The mineral ions are absorbed down the concentration gradient.

The absorption of mineral ions needs energy.

(2)

(iii) The plant in **Figure 1** has roots adapted for absorption.

Figure 2 shows a magnified part of a root from **Figure 1**.

Figure 2

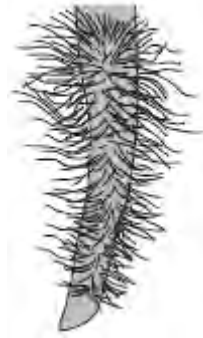

Describe how the root in **Figure 2** is adapted for absorption.

.....

.....

.....

.....

(2)

(b) The leaves of plants have stomata.

What is the function of the stomata?

.....

.....

(1)

(c) **Figure 3** shows the underside of two leaves, **A** and **B**, taken from a plant in a man's house.

Figure 3

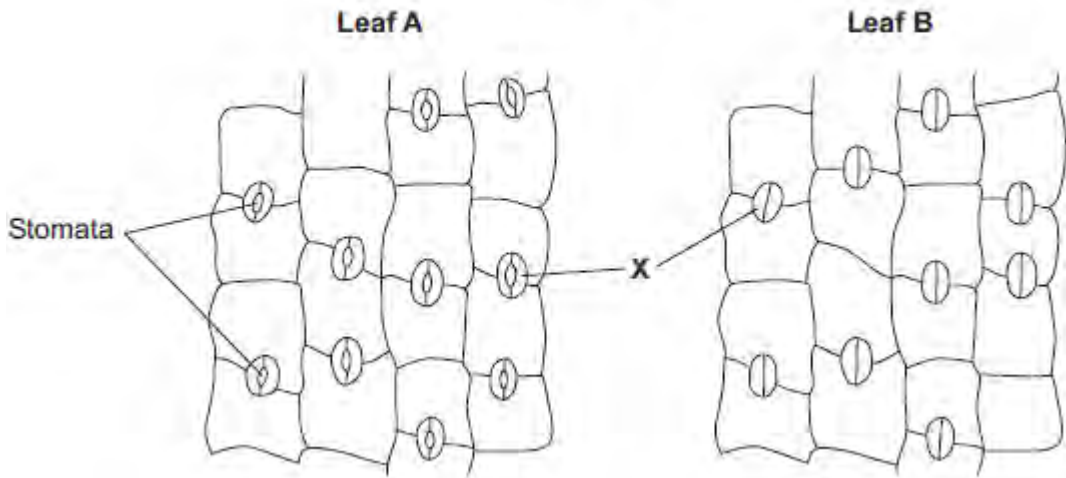

(i) In **Figure 3**, the cells labelled **X** control the size of the stomata.

What is the name of the cells labelled **X**?

Tick (✓) **one** box.

- Guard cells
- Phloem cells
- Xylem cells

(1)

(ii) Describe how the appearance of the stomata in leaf **B** is different from the appearance of the stomata in leaf **A**.

.....
.....

(1)

(iii) The man forgets to water the plant.

What might happen to the plant in the next few days if the stomata stay the same as shown in leaf **A** in **Figure 3**?

.....
.....

(1)
(Total 9 marks)

Q8.Our lungs help us to breathe.

The image below shows the human breathing system.

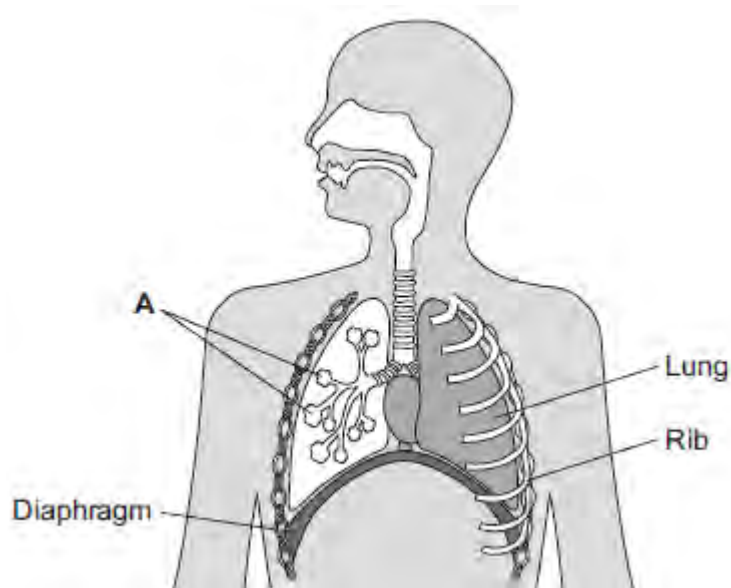

(a) (i) Name part **A**.

.....

(1)

(ii) Give **one** function of the ribs.

.....

(1)

(b) (i) Use the correct answer from the box to complete the sentence.

active transport	diffusion	osmosis
-------------------------	------------------	----------------

Oxygen moves from the air inside the lungs into the blood by the process of

(1)

(ii) Use the correct answer from the box to complete the sentence.

arteries	capillaries	veins
----------	-------------	-------

Oxygen moves from the lungs into the blood through the walls of the

(1)

(iii) Inside the lungs, oxygen is absorbed from the air into the blood.

Give **two** adaptations of the lungs that help the rapid absorption of oxygen into the blood.

1

.....

2

.....

(2)

(Total 6 marks)

- M1. (a)** (i) variation in masses / more representative / more typical / more reliable / average / mean / reference to anomalies
- or**
- one worm to light to measure change
do not allow more accurate / more precise
ignore fair test / valid / repeatable / reproducible 1
- (ii) remove solution / liquid (on outside of worm)
allow 'water' 1
- (iii) variable amounts removed from each worm
ignore reference to length of timing 1
- (iv) equal sizes of worm / more worms (in each group) / wash off all the sand / repeats / use more accurate balance / use smaller concentration intervals
allow reference to improve blotting technique eg blot before / blot more thoroughly 1
- (b) (i) different (starting) masses / sizes / weights (at different concentrations) 1
- allows comparisons / shows pattern / shows trend 1
- (ii) (+)20
correct answer = 2 marks, with or without working

or

$$\frac{7.5 \times 100}{37.5} \quad / \quad \frac{7.5}{37.5} \quad / \quad \frac{(45.0 - 1) \times 100}{37.5}$$

for 1 mark

2

(c) (i) graph:

points correct

allow ± 1 mm

-1 mark per error

allow ecf from part b(ii)

2

label on x-axis including units – ie Concentration of salt in arbitrary units

1

line of best fit = smooth curve / ruled straight line

anomaly (4.0, -52) either plotted and ignored re. line

or not plotted

do not allow point to point

allow best fit for ecf from 2bii

1

(ii) on graph:

ring drawn around point at (4.0, -52)

allow (5.0, -50) if cand. line indicates this

1

(iii) sensible suggestion – eg used wrong solution / used 5.0% instead of 4.0% / different length of time in solutions / ref to error in blotting / balance not zeroed / error in weighing

allow some lugworms died

allow error in calculation

1

(d) (i) 2.9 to 3.0 / correct for candidate's graph ± 0.1 1

value of no change in mass / worms in equilibrium with soln / described
allow small(est) mass change 1

(ii) water loss 1

by osmosis / diffusion 1

from dilute region in the worm to more concentrated solution outside
*allow correct description in terms of high to low water
concentration / high to low water potential
salt solution is hypertonic
concentration unqualified = salt concentration* 1

[19]

- M2.**
- (a) active transport 1
- (b) by transpiration stream / pull 1
- in xylem 1
- (c) any **three** in the correct order from:
- mount epidermis on a slide
 - count stomata in one area
 - repeat in four more areas
 - repeat method on other surface of leaf
 - calculate mean
- allow nail varnish film* 3
- (d) 1 1
- allow numbers written out in a line with middle number circled*
- (e) $(44 + 41 + 40 + 42 + 39) / 5 = 41.2$ 1
- 41 1
- allow 41 with no working shown for 2 marks*
- allow 41.2 for 1 mark*
- (f) less water lost 1
- so it does not wilt

M3.(a) (i) xylem 1

(ii) water 1

minerals / ions / named example(s)
ignore nutrients 1

(b) (i) movement of (dissolved) sugar
allow additional substances, eg amino acids / correct named sugar (allow sucrose / glucose)
allow nutrients / substances / food molecules if sufficiently qualified
ignore food alone 1

(ii) sugars are made in the leaves 1

so they need to be moved to other parts of the plant for respiration / growth / storage 1

(c) (i) mitochondria 1

(ii) for movement of minerals / ions
Do not accept 'water' 1

against their concentration gradient

1

[9]

M4. (a) (i)	chloroplast	1
	(ii) cell wall	1
(b) (i)	osmosis <i>accept diffusion</i>	1
	(ii) cell wall (prevents bursting)	1
(c) (i)	carbon dioxide <i>allow correct formula</i>	1
	glucose <i>allow sugar / starch</i>	1
	(ii) any two from:	
	<ul style="list-style-type: none"> • light sensitive spot detects light • tells flagellum to move towards light • more light = more photosynthesis 	2
(d)	(cell has) larger SA:volume ratio	1
	short (diffusion) distance <i>allow correct description</i>	1

(diffusion) via cell membrane is sufficient / good enough

or

flow of water maintains concentration gradient

1
[11]

M5. (a) (i) nucleus

1

(ii) diffusion

1

(b) increases / larger surface area (for diffusion)
ignore large surface area to volume ratio

1

(c) (i) sugar / glucose
accept amino acids / other named monosaccharides

1

(ii) against a concentration gradient
or
from low to high concentration

1

(iii) (active transport requires) energy

1

(from) respiration

1

(d) minerals / ions
accept named ion ignore nutrients
do not accept water

1

[8]

Q1.The lugworm lives in a U-shaped burrow in the sand on the seashore.

The diagram below shows a lugworm in its burrow.

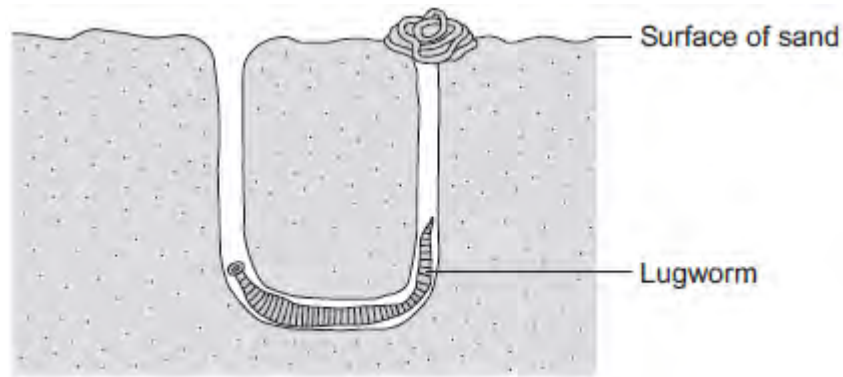

(a) Some scientists investigated the effect of different salt concentrations on lugworms.

The scientists:

- collected 50 lugworms from the seashore
- separated them into five groups of 10 lugworms
- weighed each group of 10 lugworms
- placed each group into a different concentration of salt solution and left them for 8 hours
- took each lugworm out of the solution and placed it on blotting paper for 30 seconds
- re-weighed each group of 10 lugworms.

(i) Why did the scientists use groups of 10 lugworms and not just 1 lugworm at each concentration?

.....
.....

(1)

(ii) Suggest why the scientists placed each lugworm on blotting paper for 30

seconds before they reweighed the groups of lugworms.

.....
.....

(1)

(iii) How might the method of blotting have caused errors in the results?

.....
.....

(1)

(iv) Suggest **one** improvement the scientists could make to their investigation.

.....

(1)

(b) The table below shows the scientists' results.

Concentration of salt in arbitrary units	Mass of 10 lugworms at start in grams	Mass of 10 lugworms after 8 hours in grams	Change in mass in grams	Percentage (%) change in mass
1.0	41.2	61.8	+20.6	+50
2.0	37.5	45.0	+7.5	
3.0	55.0	56.1	+1.1	+2
4.0	46.2	22.2	-24.0	-52
5.0	45.3	22.6	-22.7	-50

(i) The scientists calculated the **percentage** change in mass at each salt concentration.

Why is the **percentage** change in mass more useful than just the change in mass in grams?

Use information from the table in your answer.

.....
.....
.....
.....

(2)

- (ii) Calculate the percentage change in mass for the 10 lugworms in the salt solution with a concentration of 2.0 arbitrary units.

.....
.....

Percentage change in mass = %

(2)

- (c) (i) On the graph paper below, draw a graph to show the scientists' results:

- plot the **percentage** change in mass
- label the horizontal axis
- draw a line of best fit.

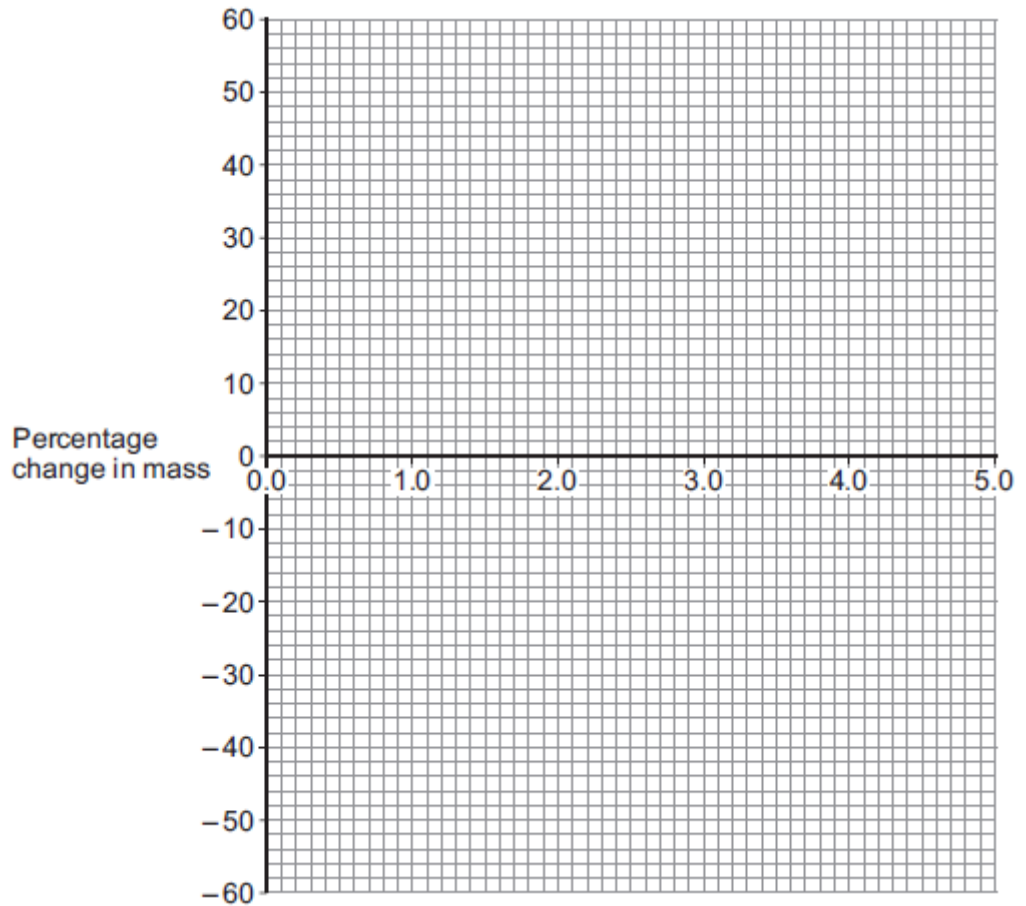

(4)

(ii) The scientists thought one of their results was anomalous.

Draw a ring around the anomalous result on your graph.

(1)

(iii) Suggest what might have happened to cause this anomalous result.

.....

(1)

(d) (i) What do you think is the concentration of salts in the lugworm's natural environment?

Use information from your graph to give the reason for your answer.

Concentration = %

Reason

.....
.....
.....

(2)

- (ii) The mass of the lugworms decreased in the salt solution with a concentration of 5.0 arbitrary units.

Explain what caused this.

.....
.....
.....
.....
.....
.....

(3)

(Total 19 marks)

Q2.Plants transport water and mineral ions from the roots to the leaves.

(a) Plants move mineral ions:

- from a low concentration in the soil
- to a high concentration in the root cells.

What process do plants use to move these minerals ions into root cells?

Tick **one** box.

Active transport	<input type="checkbox"/>
Diffusion	<input type="checkbox"/>
Evaporation	<input type="checkbox"/>
Osmosis	<input type="checkbox"/>

(1)

(b) Describe how water moves from roots to the leaves.

.....

.....

.....

.....

(2)

(c) Plants lose water through the stomata in the leaves.

The epidermis can be peeled from a leaf.

The stomata can be seen using a light microscope.

The table below shows the data a student collected from five areas on one leaf.

Leaf area	Number of stomata	
	Upper surface	Lower surface

1	3	44
2	0	41
3	1	40
4	5	42
5	1	39
Mean	2	X

Describe how the student might have collected the data.

.....

.....

.....

.....

.....

.....

.....

.....

(3)

(d) What is the median number of stomata on the upper surface of the leaf?

.....

(1)

(e) Calculate the value of **X** in the table.

Give your answer to 2 significant figures.

.....

.....

Mean number of stomata on lower surface of leaf =

(2)

- (f) The plant used in this investigation has very few stomata on the upper surface of the leaf.

Explain why this is an **advantage** to the plant.

.....

.....

.....

.....

(2)
(Total 11 marks)

Q3.The diagram below shows a cross-section of a plant root. The transport tissues are labelled.

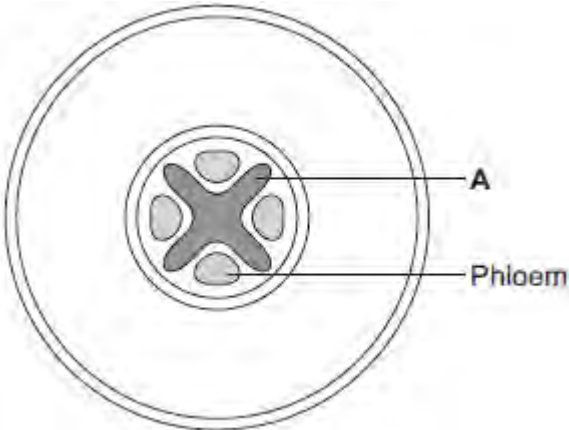

(a) (i) What is tissue **A**?

Draw a ring around the correct answer.

- cuticle**
- epidermis**
- xylem**

(1)

(ii) Name **two** substances transported by tissue **A**.

- 1
- 2

(2)

(b) Phloem is involved in a process called translocation.

(i) What is translocation?

-
-
-

(1)

(ii) Explain why translocation is important to plants.

.....
.....
.....
.....

(2)

(c) Plants must use active transport to move some substances from the soil into root hair cells.

(i) Active transport needs energy.

Which part of the cell releases most of this energy?

Tick (✓) **one** box.

- mitochondria
- nucleus
- ribosome

(1)

(ii) Explain why active transport is necessary in root hair cells.

.....
.....
.....
.....
.....
.....

(2)

(Total 9 marks)

Q4.The diagram below shows a single-celled alga which lives in fresh water.

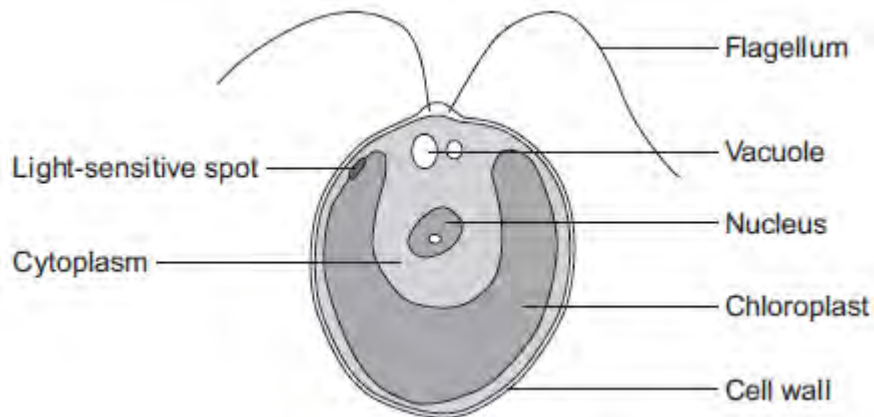

(a) Which part of the cell labelled above:

(i) traps light for photosynthesis

.....

(1)

(ii) is made of cellulose?

.....

(1)

(b) In the freshwater environment water enters the algal cell.

(i) What is the name of the process by which water moves into cells?

.....

(1)

(ii) Give the reason why the algal cell does not burst.

.....

.....

(1)

- (c) (i) The alga can photosynthesise.

Complete the **word** equation for photosynthesis.

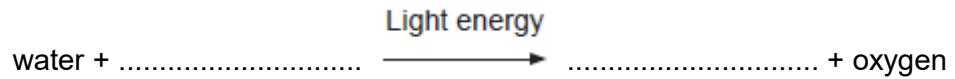

(2)

- (ii) The flagellum helps the cell to move through water. Scientists think that the flagellum and the light-sensitive spot work together to increase photosynthesis.

Suggest how this might happen.

.....
.....
.....
.....

(2)

- (d) Multicellular organisms often have complex structures, such as lungs, for gas exchange.

Explain why single-celled organisms, like algae, do **not** need complex structures for gas exchange.

.....
.....
.....
.....
.....
.....

(3)

(Total 11 marks)

Q5.The image below shows an epithelial cell from the lining of the small intestine.

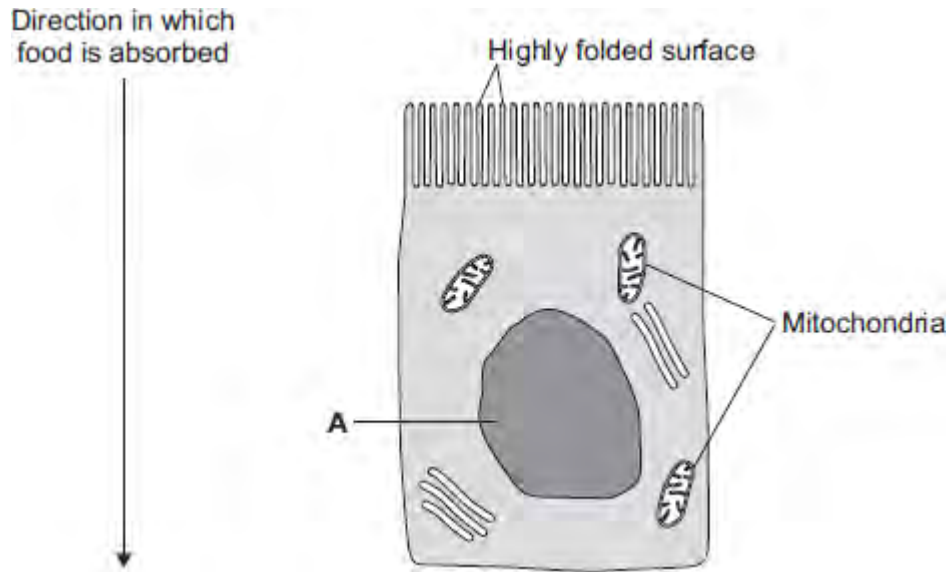

- (a) (i) In the image above, the part of the cell labelled **A** contains chromosomes.
What is the name of part **A**?

.....

(1)

- (ii) How are most soluble food molecules absorbed into the epithelial cells of the small intestine?

Draw a ring around the correct answer.

diffusion osmosis respiration

(1)

- (b) Suggest how the highly folded cell surface helps the epithelial cell to absorb soluble food.

.....
.....

(1)

- (c) Epithelial cells also carry out active transport.

(i) Name **one** food molecule absorbed into epithelial cells by active transport.

.....

(1)

(ii) Why is it necessary to absorb some food molecules by active transport?

.....

.....

(1)

(ii) Suggest why epithelial cells have many mitochondria.

.....

.....

.....

.....

(2)

(d) Some plants also carry out active transport.

Give **one** substance that plants absorb by active transport.

.....

(1)

(Total 8 marks)

- M1.** (a) glucose is absorbed by diffusion into the bloodstream 1
- then blood delivers glucose to muscles in capillaries 1
- (b) to stop air getting in 1
- (c) yellow 1
- (d) collect the CO₂ / gas with a measuring cylinder / gas syringe 1
- (volume collected) in a certain time using a timer / watch 1
- (e) yeast produces ethanol but muscles produce lactic acid
*marks can be awarded from correct word or balanced
symbol equations* 1
- yeast produces CO₂ but muscles do not
answers must be comparative 1
- both release small amounts of energy 1

ignore both occur without oxygen

[9]

- M2.** (a) (i) mitochondrion / mitochondria
must be phonetically correct 1
- (ii) carbon dioxide / CO₂ 1
- water / H₂O 1
- in either order*
*accept CO₂ but **not** CO²*
*accept H₂O **or** HOH but not H²O*
- (iii) diffusion 1
- high to low concentration
allow down a concentration gradient 1
- through (cell) membrane **or** through cytoplasm
*do **not** accept cell wall* 1
- (b) ribosomes make proteins / enzymes 1
- using amino acids 1
- part A / mitochondria provide the energy for the process
allow ATP
*do **not** accept produce or make energy* 1

[9]

M3.(a) motor

allow efferent / postsynaptic
*allow **another** relay (neurone)*

1

(b) release of chemical (from relay neurone)

allow ecf for 'motor' neurone from (a)
allow release of neurotransmitter / named example

1

chemical crosses gap / junction / synapse

allow diffuses across
allow chemical moves to X

1

chemical attaches to X / motor / next neurone (causing impulse)

1

(c) (curare) decrease / no contraction

accept (muscle) relaxes

1

(strychnine) increase / more contraction

if no other mark awarded allow 1 mark for (curare) decrease
*/ no response **and** (strychnine) increase / more response*

1

[6]

M4.(a) more concentrated
must be a comparison 1

than the cell / cytoplasm
accept more salty / solutes / ions
accept cell is less concentrated than solution for 2 marks 1

(b) (i) turgid 1

(ii) plasmolysed
accept flaccid 1

(c) any **four** from:

- water left the cells (in A)
- by osmosis
- from dilute to more concentrated solution
accept high to low water potential or from high to low water concentration
- via partially permeable membrane
- so cell membrane shrank away from cell wall

4

(d) water enters the cells (by osmosis)
allow 1 mark for: 1

they burst / lyse / lysis occurs
water leaves and cell shrinks (if they think it is hypertonic solution) 1

animal cells have no cell wall **or** plant cells have a cell wall 1

cell wall prevents lysis / bursting / allows turgidity
allow correct description 1

[12]

- M5.(a) (i) diaphragm
accept phonetic spelling 1
- (ii) (because) the volume (inside the jar) increases
maximum two marks if no reference to correct part of model 1
- (causing) the pressure to decrease 1
- (and) air enters the balloon
allow oxygen 1
- (b) (i) (so it moves by) diffusion
do not allow osmosis or active transport 1
- from a high concentration (of oxygen) to a low concentration
*allow down its / oxygen concentration gradient from the air
or to the blood*
- or**
(because) there is a high(er) concentration (of oxygen) in the air **or** there is a low(er) concentration of oxygen in the blood
ignore reference to amount of oxygen 1
- (ii) many gill filaments
must be in the correct pairs to gain 2 marks 1
- (give a) large surface / area
do not allow surface area to volume ratio
- or**
thin
(so) short diffusion pathway
or
good blood supply
(to) maintain the concentration gradient
or
water continually flows over them / continually ventilated
(to) maintain the concentration gradient 1

[8]

M6.	(a)	$(0.15 / 1.35) \times 100$	1
		11.1 (%)	
		<i>allow 11.1 (%) with no working shown for 2 marks</i>	1
	(b)	to allow results to be compared or they had different masses at the start	1
	(c)	axis correct scale and labelled	1
		5 points correctly plotted	
		<i>allow ecf from 05.1</i>	
		<i>allow 1 mark for 4 points correctly plotted</i>	2
		line of best fit	1
	(d)	0.5	
		<i>allow 0.45–0.55</i>	1
	(e)	(0.0 to 0.4) water moves into cells	1
		(0.6 to 0.8) water leaves cells	1

by osmosis

1

- (f) any **two** from:
- concentration of solutions
 - drying of chips
 - accuracy of balance
 - evaporation from tubes

2

[13]

Q1.All living cells respire.

- (a) Respiration transfers energy from glucose for muscle contraction.

Describe how glucose from the small intestine is moved to a muscle cell.

.....

.....

.....

.....

(2)

- (b) The diagram below shows an experiment to investigate **anaerobic** respiration in yeast cells.

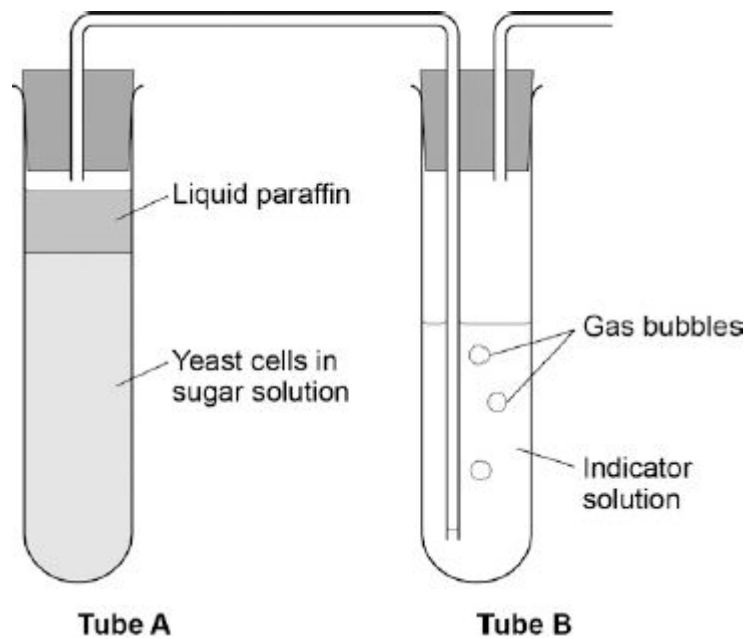

What is the purpose of the liquid paraffin in Tube A?

Tick **one** box.

To prevent evaporation

To stop air getting in

To stop the temperature going up

To stop water getting in

(1)

(c) The indicator solution in Tube **B** shows changes in the concentration of carbon dioxide (CO₂).

The indicator is:

- **blue** when the concentration of CO₂ is very low
- **green** when the concentration of CO₂ is low
- **yellow** when the concentration of CO₂ is high.

What colour would you expect the indicator to be in Tube **B** during maximum rate of anaerobic respiration?

Tick **one** box.

Blue

Green

Yellow

(1)

(d) Suggest how the experiment could be changed to give a reproducible way to measure the rate of the reaction.

Include any apparatus you would use.

.....

.....

.....

.....

(2)

- (e) Compare anaerobic respiration in a yeast cell with anaerobic respiration in a muscle cell.

.....

.....

.....

.....

.....

.....

.....

.....

(3)
(Total 9 marks)

Q2. Diagram 1 shows a cell from the pancreas.

Diagram 2 shows part of the cell seen under an electron microscope.

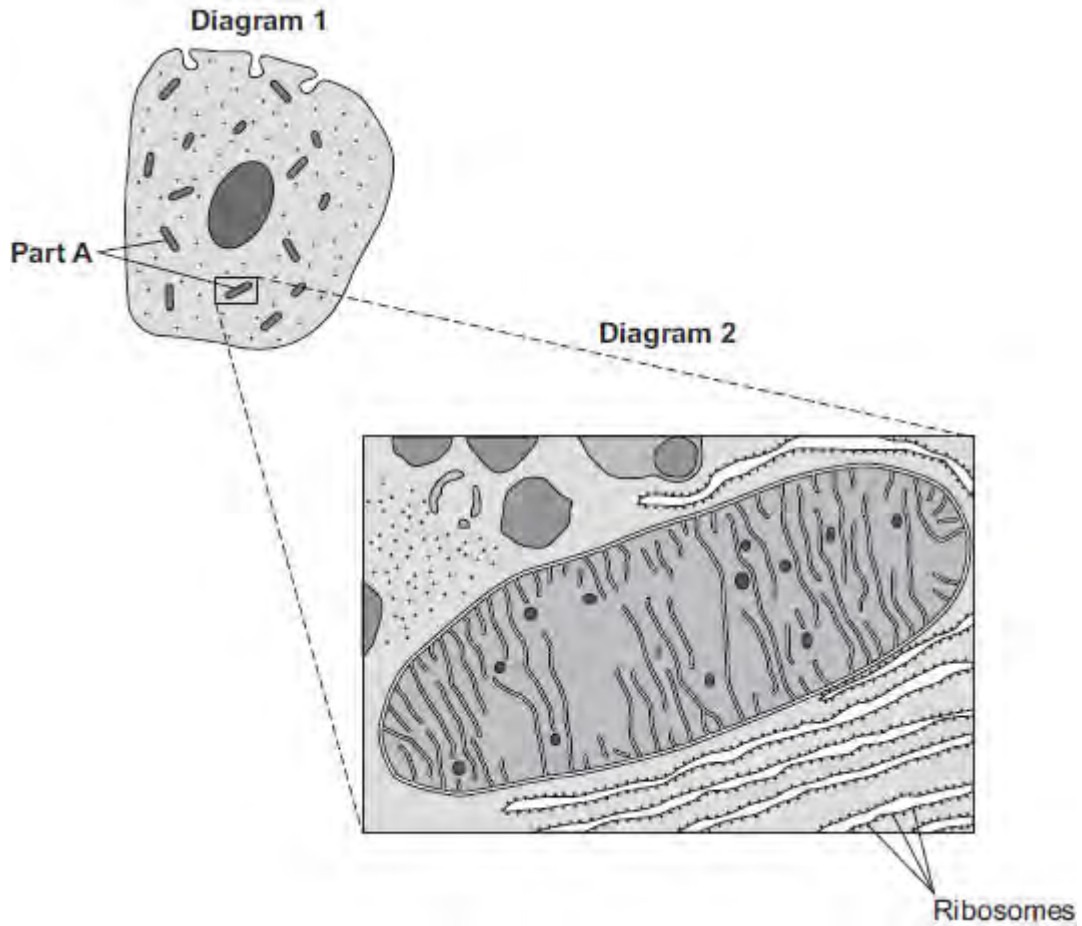

Part **A** is where most of the reactions of aerobic respiration happen.

(a) (i) Name part **A**.

.....

(1)

(ii) Complete the equation for aerobic respiration.



(2)

(iii) Part **A** uses oxygen.

Explain how oxygen passes from the blood to part **A**.

.....

.....

.....

.....

.....

.....

.....

.....

.....

(3)

(b) The pancreas cell makes enzymes.

Enzymes are proteins.

Describe how the ribosomes and part **A** help the cell to make enzymes.

.....

.....

.....

.....

.....

.....

.....

.....

(3)

(Total 9 marks)

Q3. The diagram below shows how a nerve impulse passing along a relay neurone causes an impulse to be sent along another type of neurone, neurone **X**.

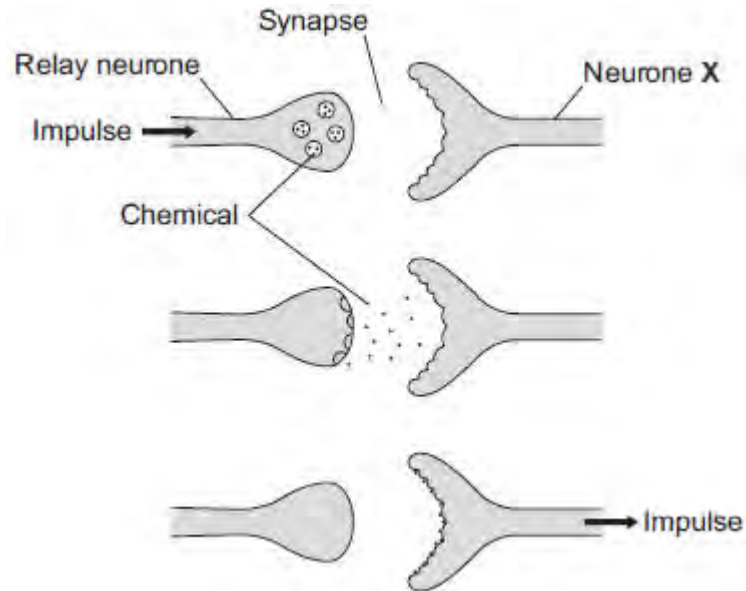

(a) What type of neurone is neurone **X**?

.....

(1)

(b) Describe how information passes from the relay neurone to neurone **X**.
Use the diagram to help you.

.....

(3)

- (c) Scientists investigated the effect of two toxins on the way in which information passes across synapses. The table below shows the results.

Toxin	Effect at the synapse
Curare	Decreases the effect of the chemical on neurone X
Strychnine	Increases the amount of the chemical made in the relay neurone

Describe the effect of each of the toxins on the response by muscles.

Curare

.....

.....

Strychnine

.....

.....

(2)
(Total 6 marks)

Q4.The photographs show the same cells of a common pond plant.

Photograph A shows the cells in a hypotonic solution.

Photograph B shows the same cells in a hypertonic solution.

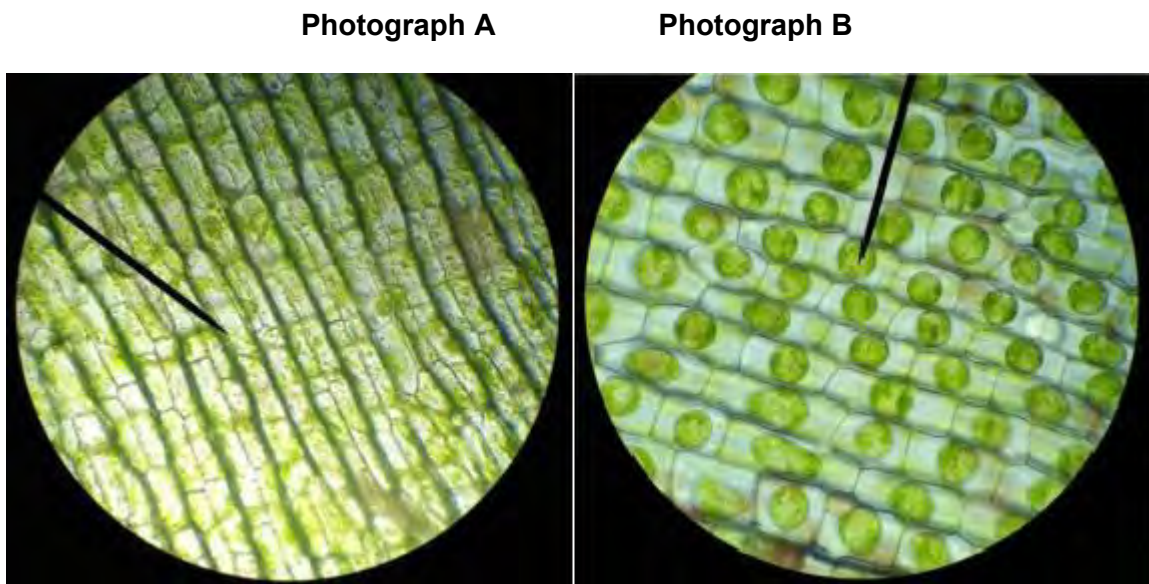

A & B AELODEA IN HYPOTONIC SOLUTION by ficklendfreckled [CC- BY-2.0], via Flickr.

(a) What is a **hypertonic** solution?

.....

.....

.....

.....

(2)

(b) What word is used to describe plant cells placed in:

(i) a **hypotonic** solution

.....

(1)

(ii) a **hypertonic** solution?

.....

(1)

(c) Explain what has happened to the plant cells in **Photograph B**.

.....
.....
.....
.....
.....
.....
.....
.....
.....

(4)

(d) Animal cells will also change when placed in different solutions.

Some red blood cells are put in a hypotonic solution.

Describe what would happen to these red blood cells **and** explain why this is different from what happened to the plant cells in **Photograph A**.

.....
.....
.....
.....
.....
.....

.....
.....
.....
.....

(4)
(Total 12 marks)

Q5.Figure 1 shows a model representing the human breathing system.

The different parts of the model represent different parts of the human breathing system.

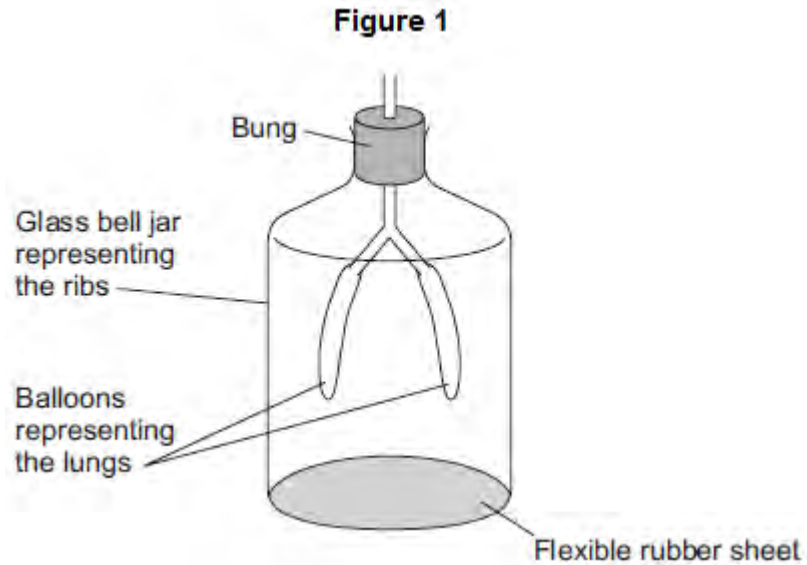

- (a) (i) Which part of the human breathing system does the flexible rubber sheet represent?

.....

(1)

- (ii) Explain why the balloons inflate when the flexible rubber sheet is pulled down.

.....
.....
.....
.....
.....
.....

(3)

- (b) (i) During breathing, oxygen moves into the blood.

Explain how oxygen moves into the blood.

.....

.....
.....
.....

(2)

(ii) **Figure 2** shows a fish head and gill.

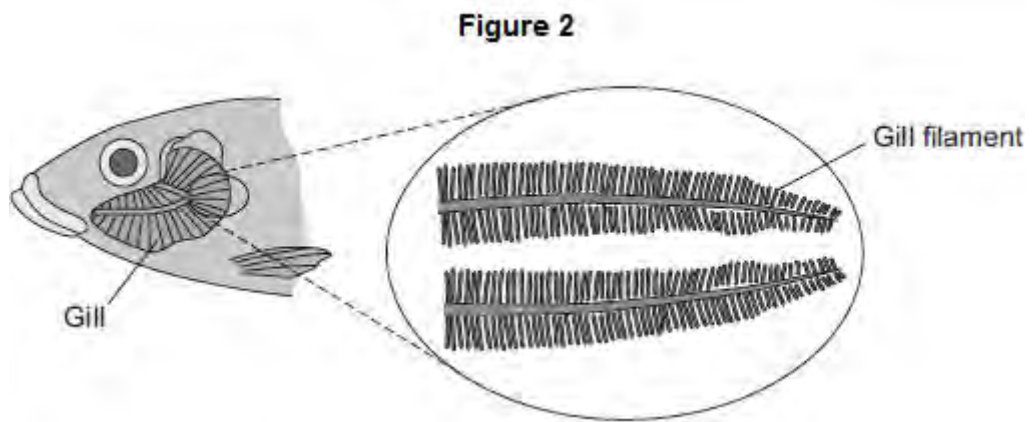

Fish absorb oxygen from the water. Oxygen is absorbed through the gills of the fish.

Explain **one** way in which the gills are adapted for rapid absorption of oxygen.

.....
.....
.....
.....

(2)
(Total 8 marks)

Q6.A A student investigated the effect of different sugar solutions on potato tissue.

This is the method used.

1. Add 30 cm³ of 0.8 mol dm⁻³ sugar solution to a boiling tube.
2. Repeat step 1 with equal volumes of 0.6, 0.4 and 0.2 mol dm⁻³ sugar solutions.
3. Use water to give a concentration of 0.0 mol dm⁻³.
4. Cut five cylinders of potato of equal size using a cork borer.
5. Weigh each potato cylinder and place one in each tube.
6. Remove the potato cylinders from the solutions after 24 hours.
7. Dry each potato cylinder with a paper towel.
8. Reweigh the potato cylinders.

The table below shows the results.

Concentration of sugar solution in mol dm ⁻³	Starting mass in g	Final mass in g	Change of mass in g	Percentage (%) change
0.0	1.30	1.51	0.21	16.2
0.2	1.35	1.50	0.15	X
0.4	1.30	1.35	0.05	3.8
0.6	1.34	1.28	-0.06	-4.5
0.8	1.22	1.11	-0.11	-9.0

(a) Calculate the value of **X** in the table above.

.....
.....

Percentage change in mass = %

(2)

(b) Why did the student calculate the percentage change in mass as well as the change in grams?

.....
.....

(1)

(c) Complete the graph using data from the table above.

- Choose a suitable scale and label for the x-axis.
- Plot the percentage (%) change in mass.
- Draw a line of best fit.

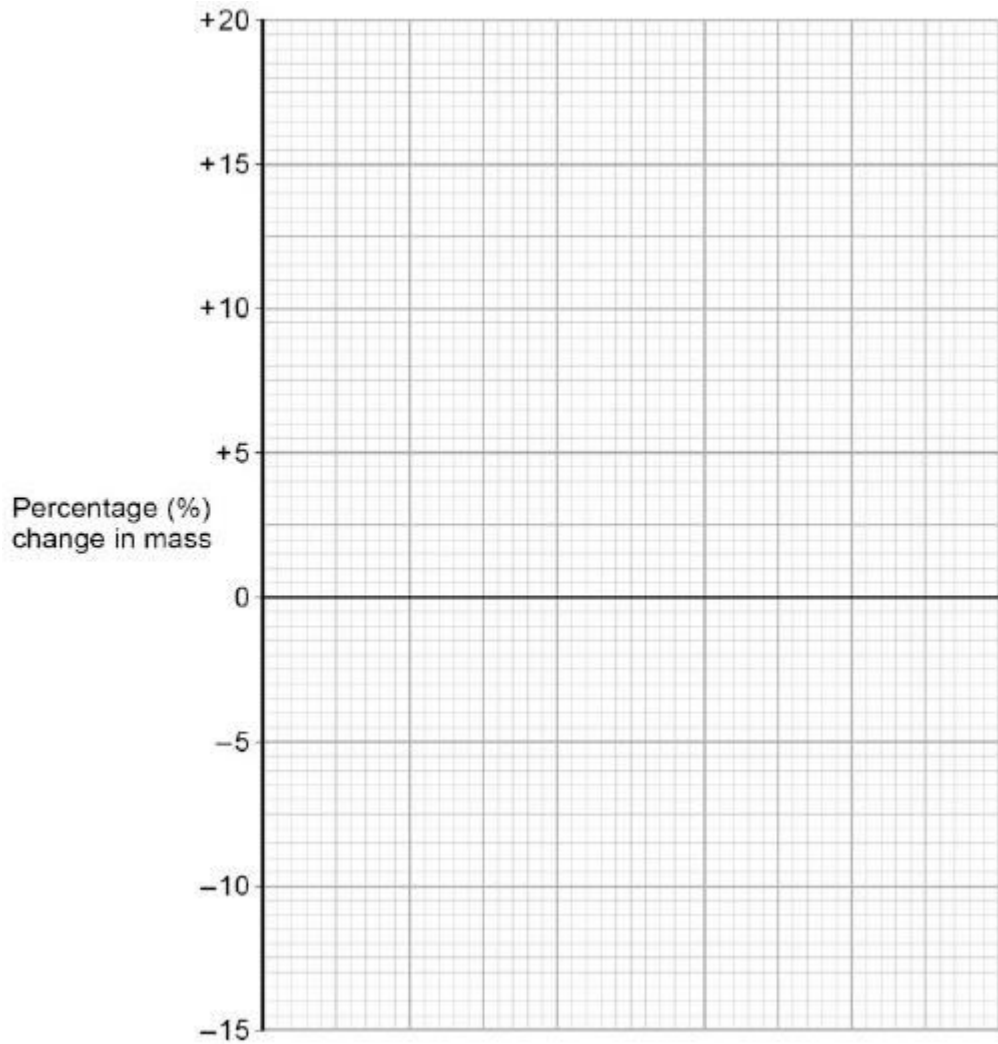

(4)

(d) Use your graph to estimate the concentration of the solution inside the potato cells.

Concentration = mol dm⁻³

(1)

(e) The results in the table above show the percentage change in mass of the potato cylinders.

Explain why the percentage change results are positive **and** negative.

.....

.....
.....
.....
.....
.....
.....
.....

(3)

(f) Suggest **two** possible sources of error in the method given above.

1.....
.....
2.....
.....

(2)

(Total 13 marks)